



V1504

VERTICAL PLATFORM LIFT

PLANNING GUIDE

Applicable Codes:

ASME A17.1

ASME A18.1

CAN/CSA B355

Copyright © 2010
Savaria Corporation
All rights reserved.

Printed in Canada

Purpose of This Guide

This guide assists architects, contractors, and lift professionals to incorporate the V1504 Vertical Platform Lift into a residential or public building design. The design and manufacture of the V1504 Vertical Platform Lift meets the requirements of the ASME A17.1, ASME A18.1 and CSA B355 Safety Standards.

We recommend that you contact your local authority having jurisdiction to ensure that you adhere to all local rules and regulations pertaining to vertical platform lifts.

IMPORTANT: This Planning Guide provides nominal dimensions and specifications useful for the initial planning of a vertical platform lift project. Dimensions and specifications are subject to change without notice due to continually evolving code and product applications.

Before beginning actual construction, please consult Savaria Corporation or the authorized Savaria dealer in your area to ensure you receive your site-specific installation drawings with the dimensions and specifications for your project.

Visit our website for the most recent V1504 drawings and dimensions.

How to Use This Guide

- 1 Determine your client's intended use of the lift.
- 2 Determine the local code requirements.
- 3 Determine the site installation parameters.
- 4 Determine the cab type and hoistway size requirements.
- 5 Plan for electrical requirements.

History

April 6, 2010

- Initial release

Specifications

V1504 Specifications

Specification	Specification Data
Load capacity	750 lb (340 kg)
Maximum travel	23 ft (7 m)
Travel speed	25 ft/min (0.127 m/s)
Levels serviced	2 (standard), 3, 4
Cab sizes	36" x 48" (914 mm x 1219 mm) 36" x 54" (914 mm x 1371 mm) 36" x 60" (914 mm x 1524 mm)
Side guard panels	42-1/8" (1070 mm) high side guard panels on platform
Cab access	Enter/exit same side (platform Type 1L and 1R) Front/rear access (platform Type 2) 90 degree access (platform Type 3 and 4)
Power supply	120 VAC, 20 A, 60 Hz, single phase
Motor/pump	110 VAC, 1.5 hp (1.12 kW) Gear type hydraulic pump
Control system	Electronic-free relay logic controller
Drive system	2:1 chain hydraulic drive system
Tower	Modular 8 ft (2.4 m) base guide rail assembly Roller guide support
Pit depth requirement	3" (76.2 mm)
Finish	Beige electrostatic powder coat paint on all steel surfaces and vacuumed formed plastics
Standard features	115 VAC operation (115 VAC up direction; 12 VDC battery down direction) Call/send stations at landings Continuous-pressure type buttons Operating control buttons on platform Automatic battery recharging system (115 VAC) Remote manual lowering device Low-voltage controls Limit switches Handrail Non-skid platform surface No machine room required Emergency stop button
Safety features	Platform gate Safety underpan Door locks Safety brake Emergency stop buttons Manual lowering and battery lowering system

V1504 Specifications

Specification	Specification Data
Options	Platform gate with metal insert and electric strike Top landing gate Upper/lower landing door 80" (2032 mm) Fire-rated, flush-mounted landing entrances Folding seat on platform Telephone on platform Custom color Fixed access ramp Public building package Outdoor package Automatic safety ramp on platform (for outdoor model)

Site Construction Details

The V1504 needs a wall that supports a minimum of 472 lb (2100 N) of pull out force at any bracket. The floor must be capable of supporting a load of 3200 lb (14.2 kN). See Figure 1. A wall with a combination of two columns of three 2x4's, or a concrete or brick wall is required.

Figure 2 details a sample wooden support wall configuration

Figure 1: Wall/Floor Loading

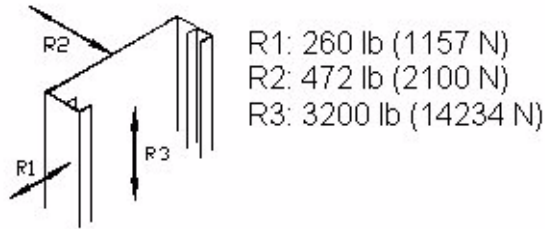

Figure 2: Sample Wooden Support Wall Configuration

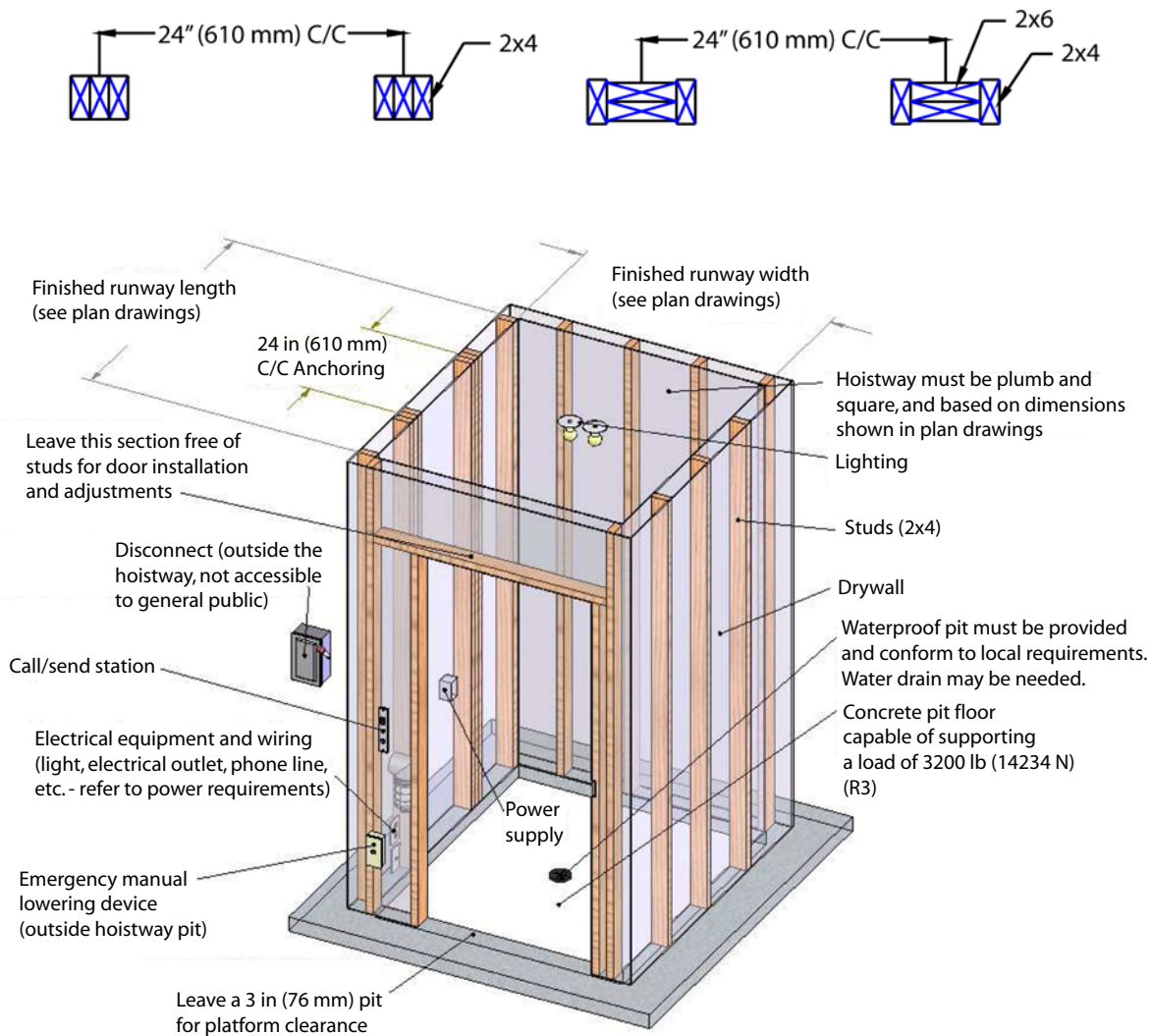

Figure 3 illustrates the recommended steps for constructing a wooden hoistway.

Figure 3: Wooden Hoistway Construction - Recommended Steps

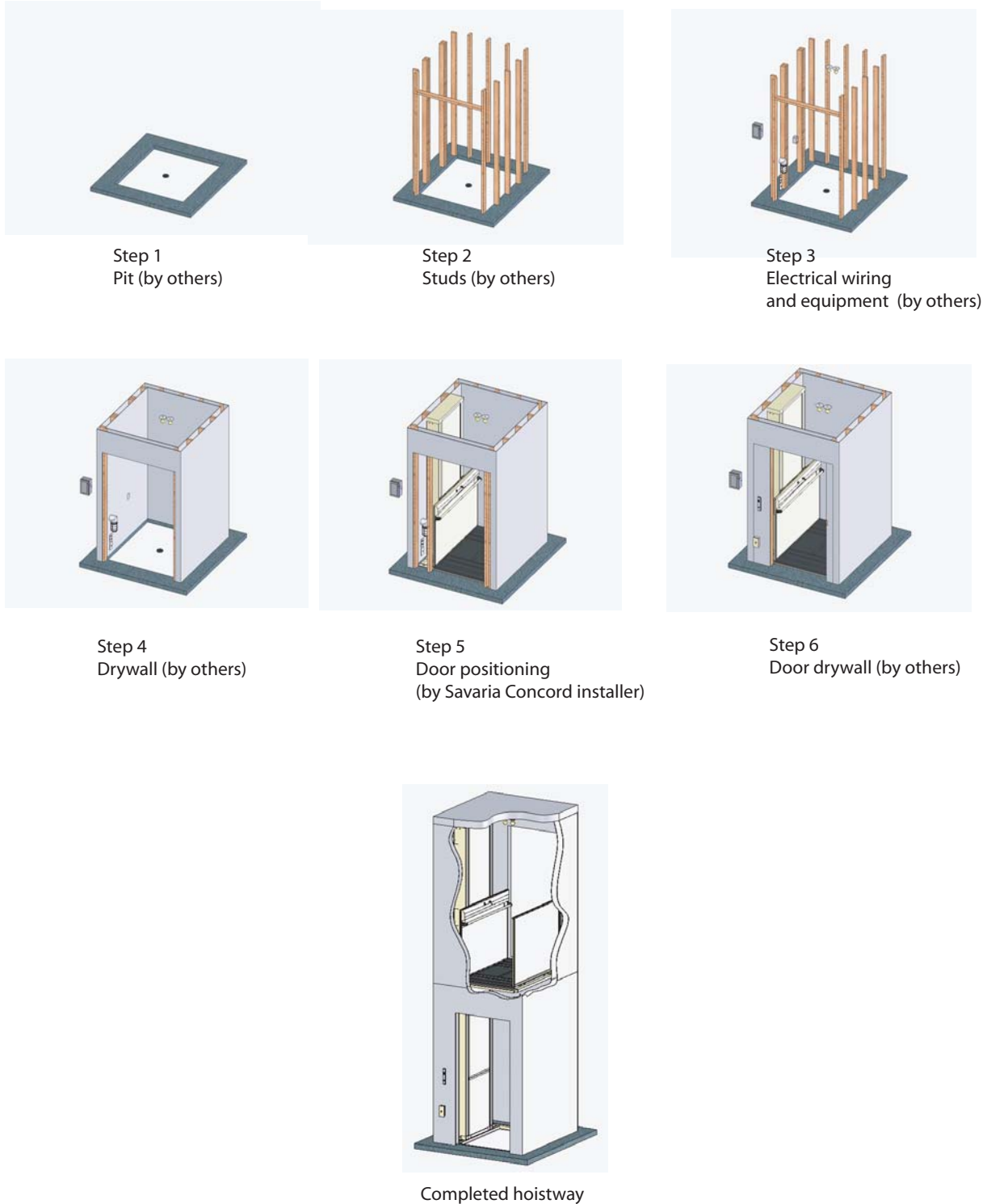
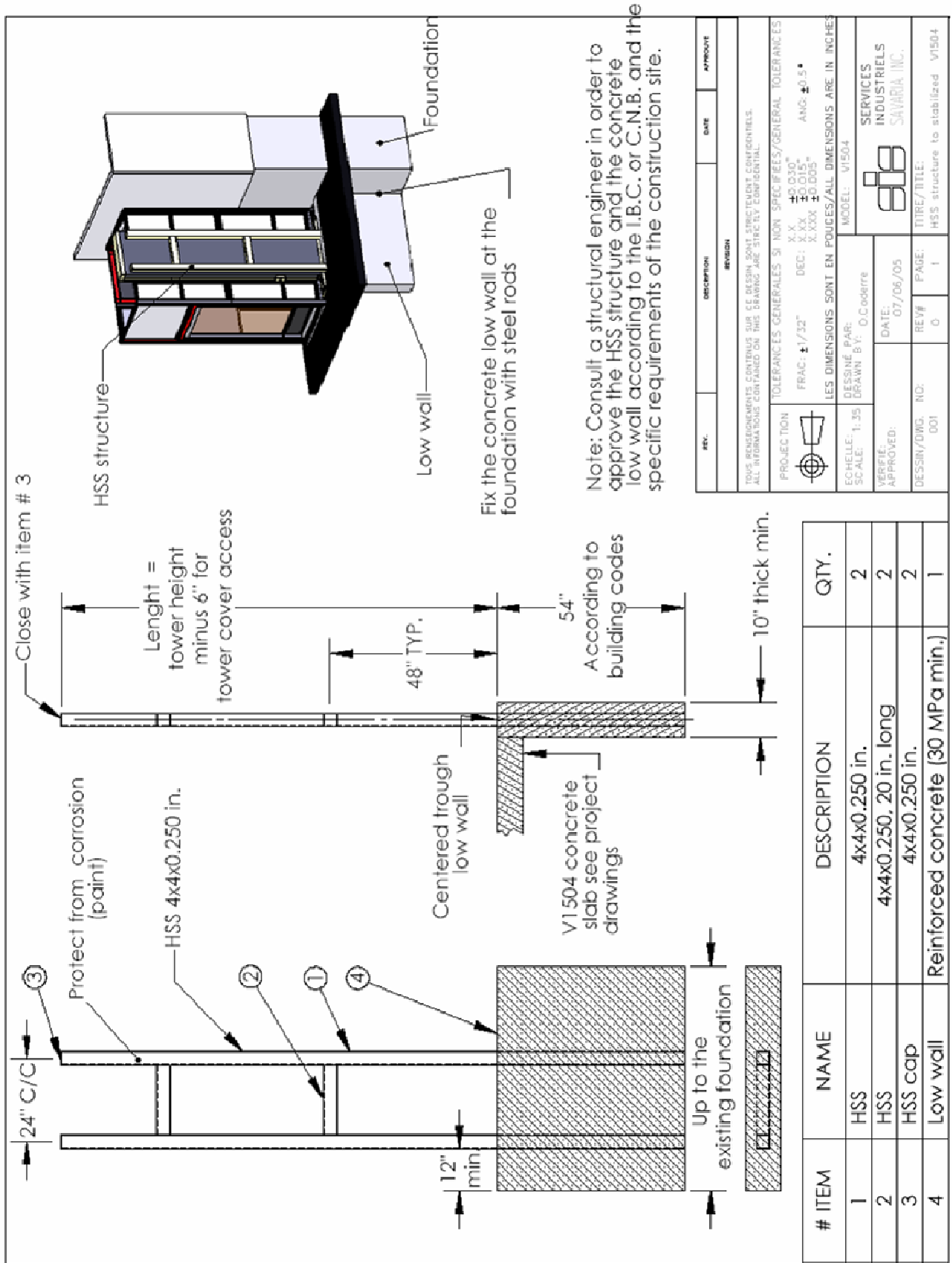

Figure 4 illustrates a sample concrete/steel structure configuration.

Figure 4: Sample Concrete/Steel Structure Configuration



REV.	DESCRIPTION	DATE	APPROVE
REVISION			
<small>NOTE: REPERMITS CONTAINS THE DESIGN DATA SUBJECT TO CONFIDENTIALITY. ALL INFORMATION CONTAINED ON THIS DRAWING ARE STRICTLY CONFIDENTIAL.</small>			
PROJECTION 			
TOLERANCES GENERALES SI NON SPECIFIEES/GENERAL TOLERANCES FRAC: 1/32" DEC: 0.030" ANG: 0.5° X.XXX ±0.015" X.XXX ±0.005"			
ECHELLE: 1:35 DESSIN PAR: O.Codre SCALE: 1:35 DRAWN BY: O.Codre		MODEL: V1504	
APPROVED:		DATE: 07/06/05	
DESSIN/DWG. NO: 001		REV# PAGE: 0 1	
TITRE/TITLE: HSS structure to stabilized V1504		SERVICES INDUSTRIELS SAVARIA INC.	

# ITEM	NAME	DESCRIPTION	QTY.
1	HSS	4x4x0.250 in.	2
2	HSS	4x4x0.250, 20 in. long	2
3	HSS cap	4x4x0.250 in.	2
4	Low wall	Reinforced concrete (30 MPa min.)	1

Figure 5 illustrates a sample outdoor enclosure application.

Figure 5: Sample Outdoor Enclosure Application

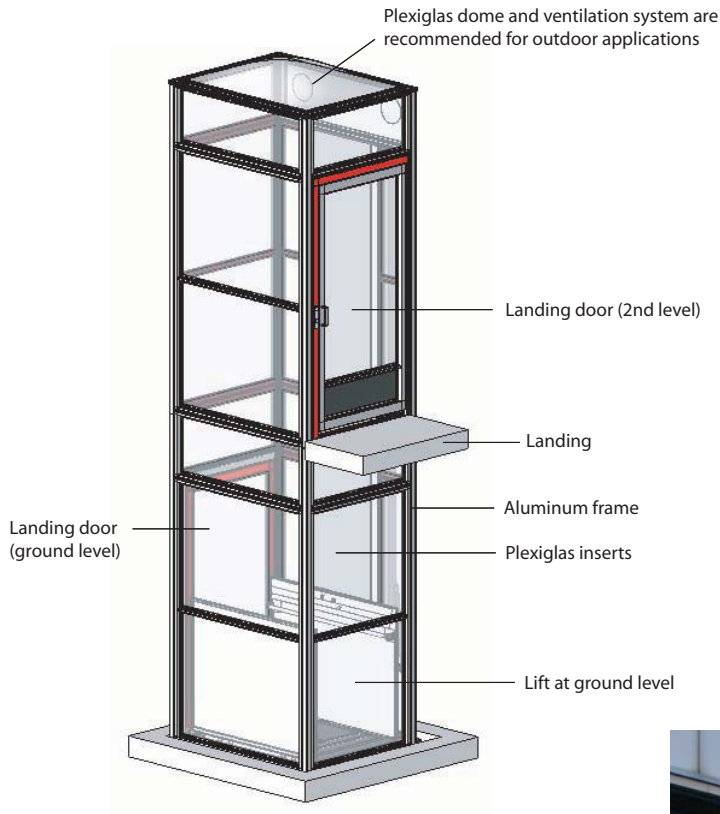

Figure 6 illustrates the site construction details for a typical outdoor application.

Figure 6: Sample Unenclosed Outdoor Application

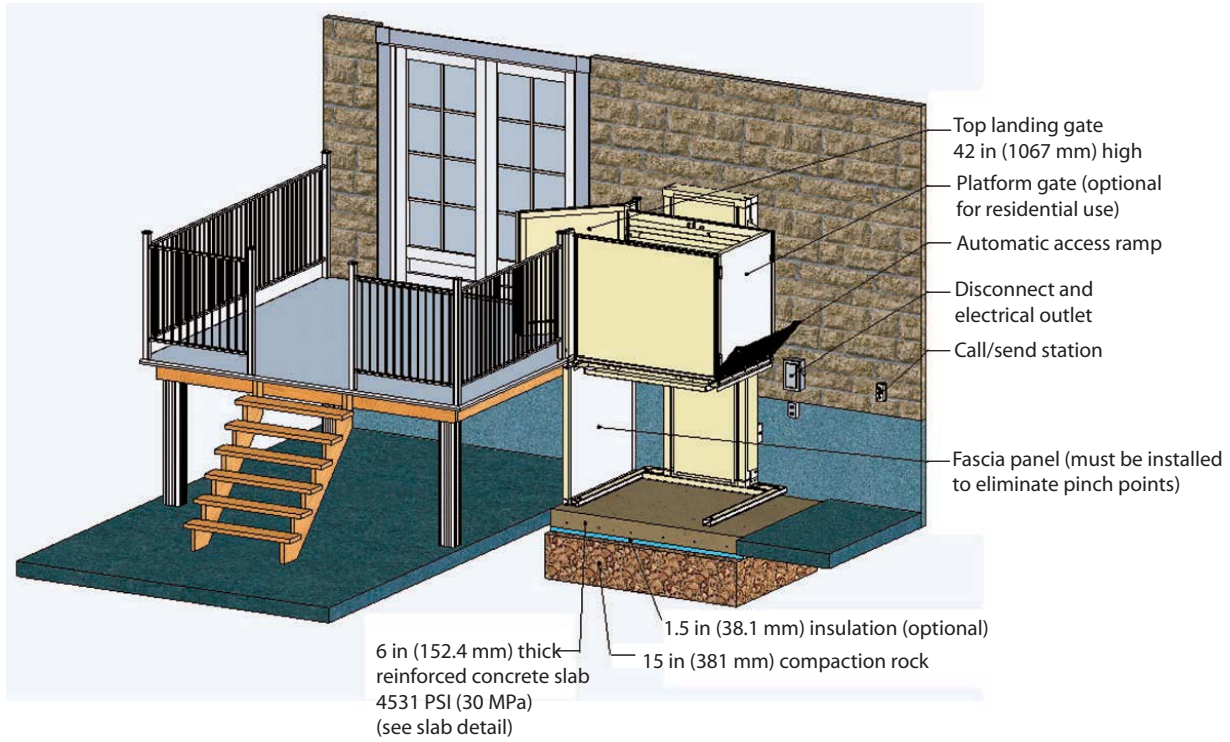
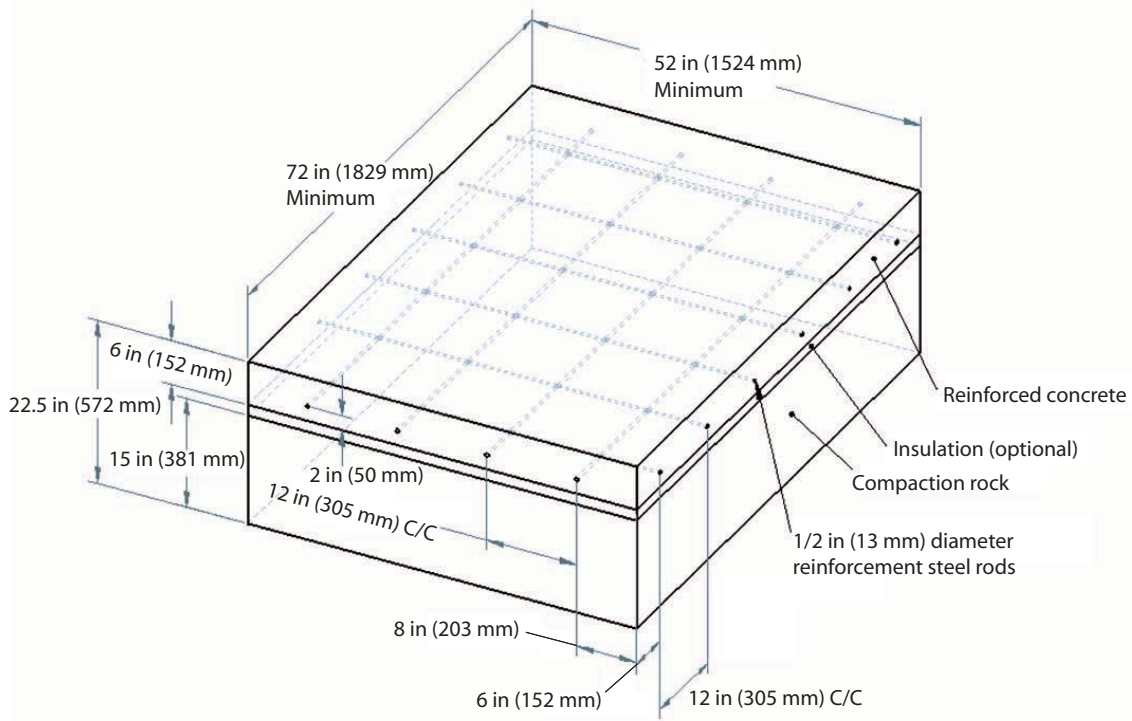

Figure 7 illustrates the concrete slab detail for a typical outdoor application.

Figure 7: Concrete Slab Detail



Cab Types

Type 1 Cabs

For type 1 cabs, entry and exit are available from only one end of the platform.

Figure 8: Type 1 Left and Right

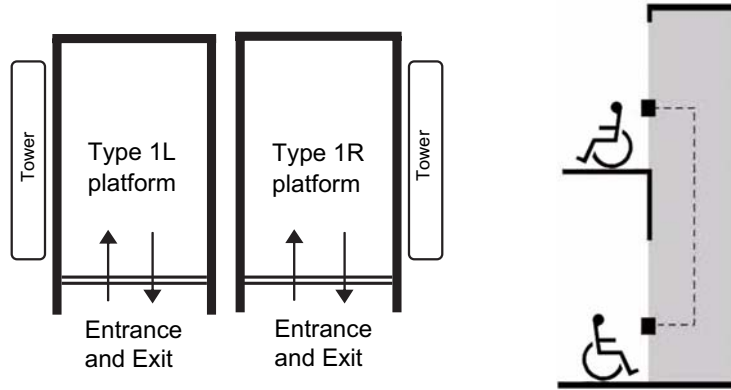

Type 2 Cabs

For type 2 cabs, entry and exit are available from both ends of the platform.

Figure 9: Type 2

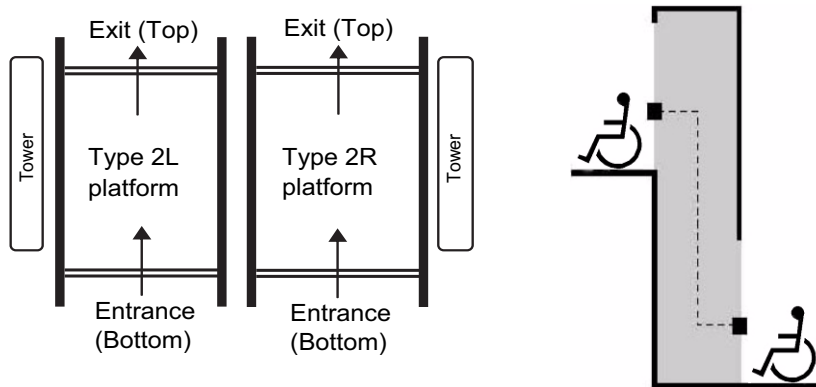

Type 3 and 4 Cabs

For type 3 and 4 cabs, entry and exit are available from one end and one side of the platform.

Figure 10: Type 3 and 4

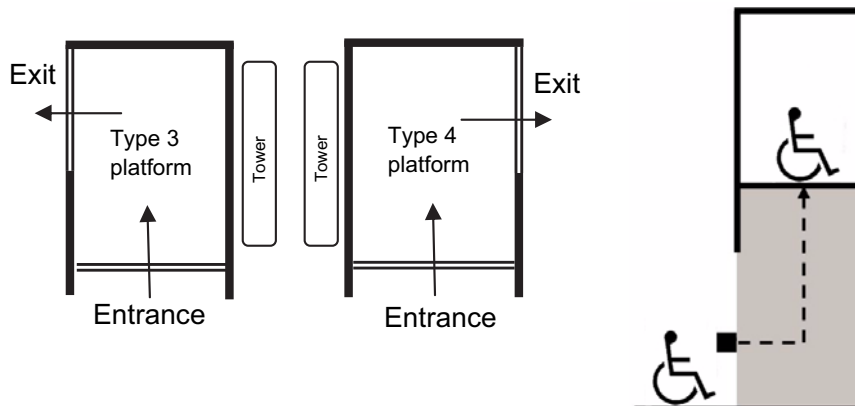

Drawings

The next several pages provide hoistway and plan view drawings:

- Hoistway drawing (Type 1 shown)
- Plan view drawings (for the different cab types and sizes)
 - Type 1L, 36" x 48", hoistway application
 - Type 1L, 36" x 48", enclosure application
 - Type 1L, 36" x 54", hoistway application
 - Type 1L, 36" x 54", enclosure application
 - Type 1L, 36" x 60", hoistway application
 - Type 1L, 36" x 60", enclosure application

 - Type 1R, 36" x 48" cab, hoistway application
 - Type 1R, 36" x 48" cab, enclosure application
 - Type 1R, 36" x 54" cab, hoistway application
 - Type 1R, 36" x 54" cab, enclosure application
 - Type 1R, 36" x 60" cab, hoistway application
 - Type 1R, 36" x 60" cab, enclosure application

 - Type 2, 36" x 48" cab, hoistway application
 - Type 2, 36" x 48" cab, enclosure application
 - Type 2, 36" x 54" cab, hoistway application
 - Type 2, 36" x 54" cab, enclosure application
 - Type 2, 36" x 60" cab, hoistway application
 - Type 2, 36" x 60" cab, enclosure application

 - Type 3, 36" x 48" cab, hoistway application
 - Type 3, 36" x 48" cab, enclosure application
 - Type 3, 36" x 54" cab, hoistway application
 - Type 3, 36" x 54" cab, enclosure application
 - Type 3, 36" x 60" cab, hoistway application
 - Type 3, 36" x 60" cab, enclosure application

 - Type 4, 36" x 48" cab, hoistway application
 - Type 4, 36" x 48" cab, enclosure application
 - Type 4, 36" x 54" cab, hoistway application
 - Type 4, 36" x 54" cab, enclosure application
 - Type 4, 36" x 60" cab, hoistway application
 - Type 4, 36" x 60" cab, enclosure application
- Sample installation drawings (for a hoistway application)
 - NOTE:** These are sample installation drawings only. Be sure to refer to the site-specific installation drawings that came with your lift for the correct dimensions and specifications.
- Gates and doors
- Door plan view (right hand shown)

Figure 11: Hoistway Drawing (Type 1 Shown)

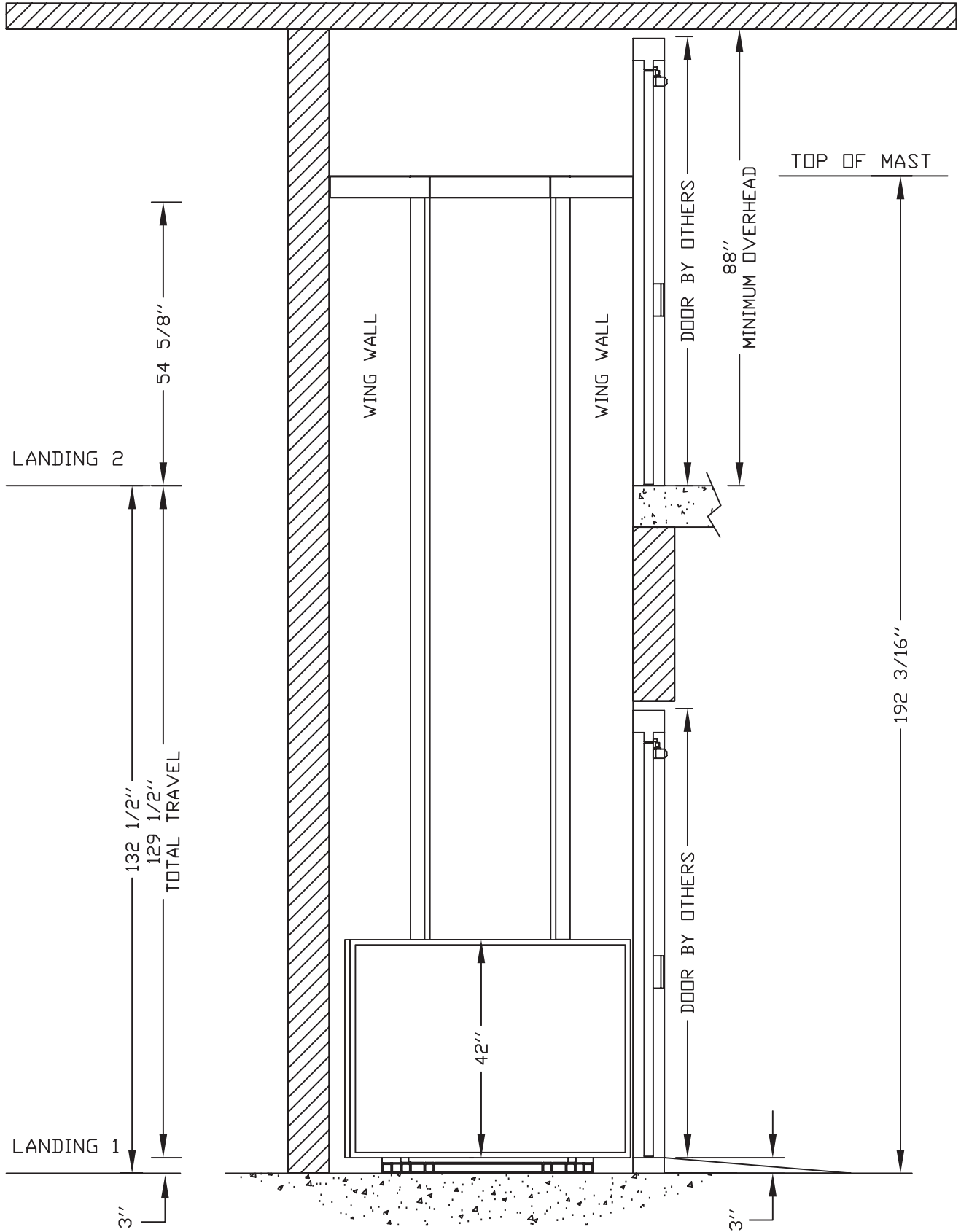

Figure 12: Plan View - Type 1L, 36" x 48" Cab, Hoistway Application

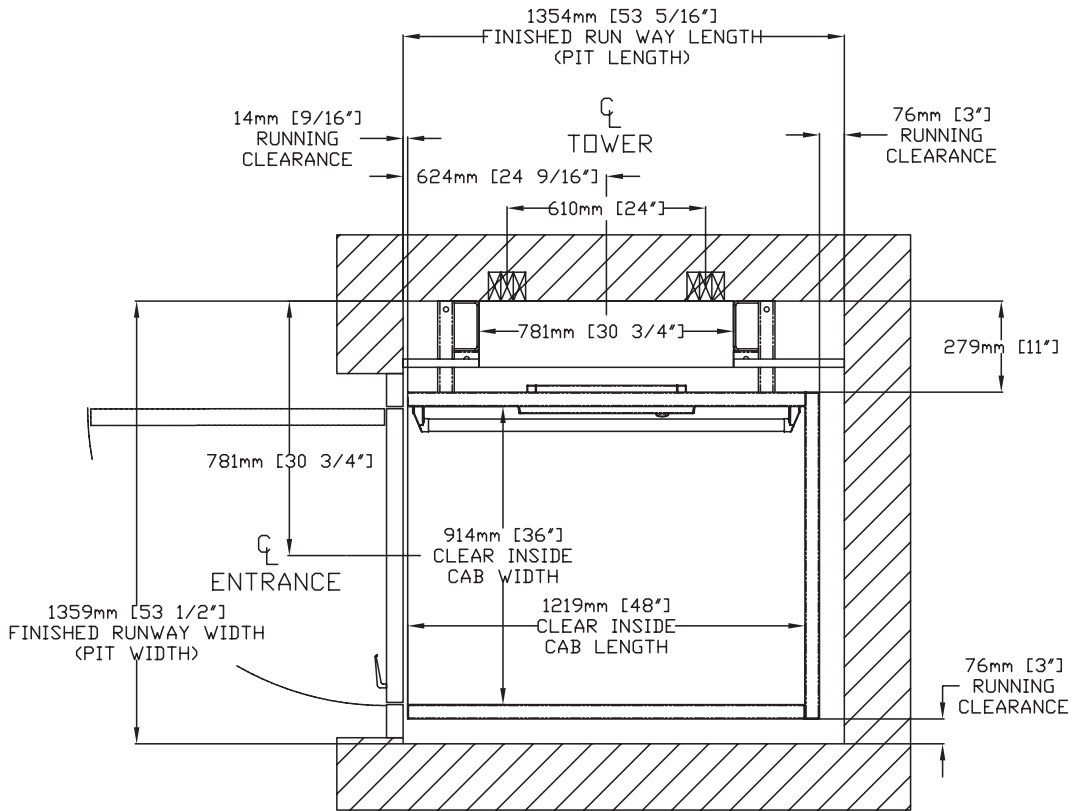

Figure 13: Plan View - Type 1L, 36" x 48" Cab, Enclosure Application

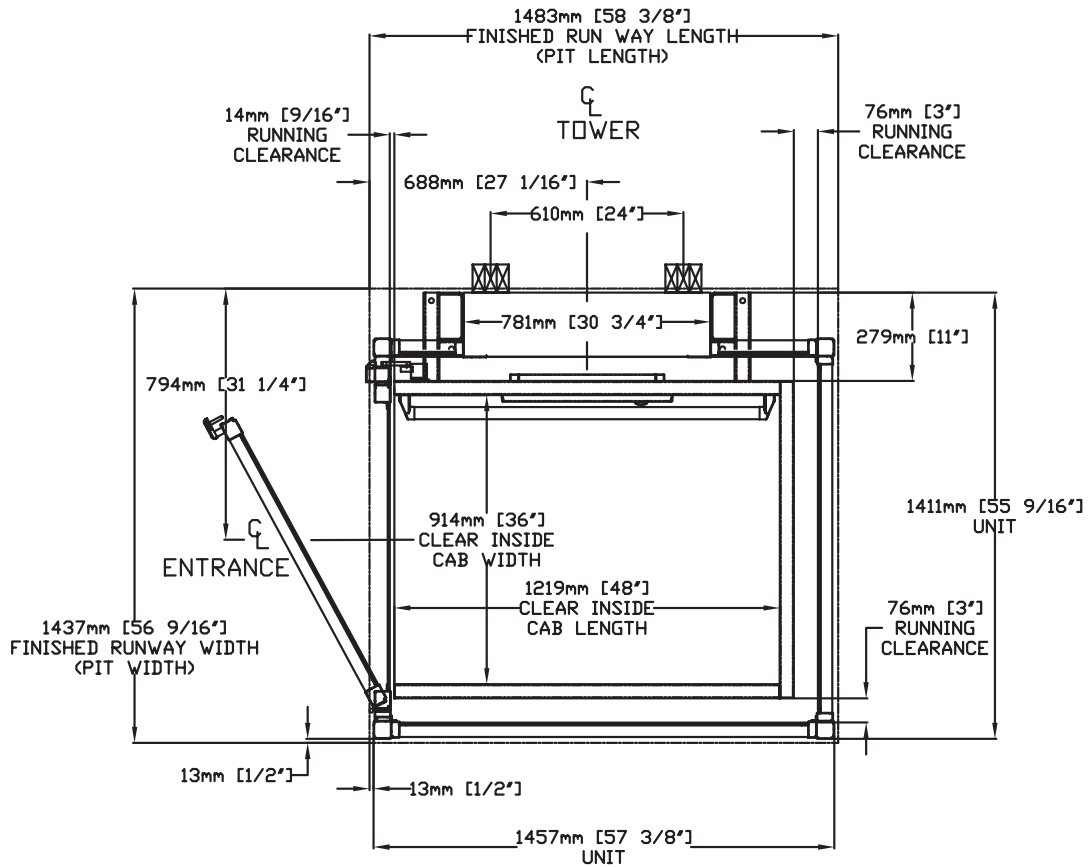

Figure 14: Plan View - Type 1L, 36" x 54" Cab, Hoistway Application

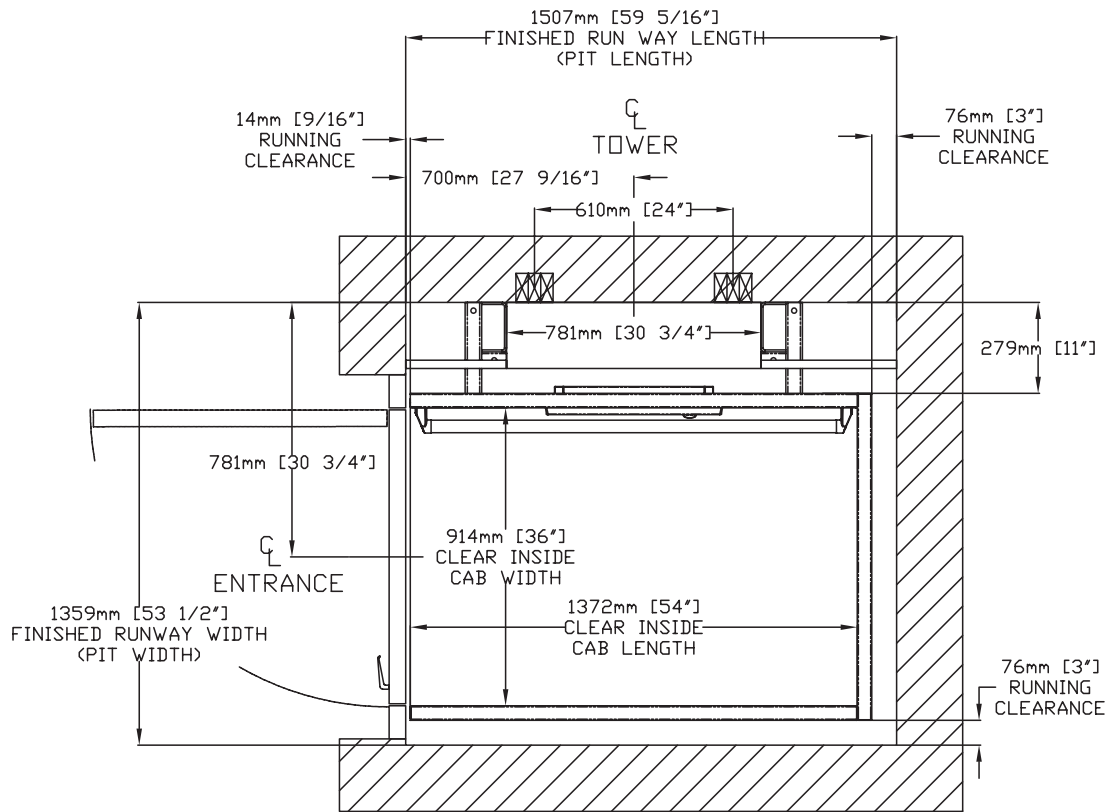

Figure 15: Plan View - Type 1L, 36" x 54" Cab, Enclosure Application

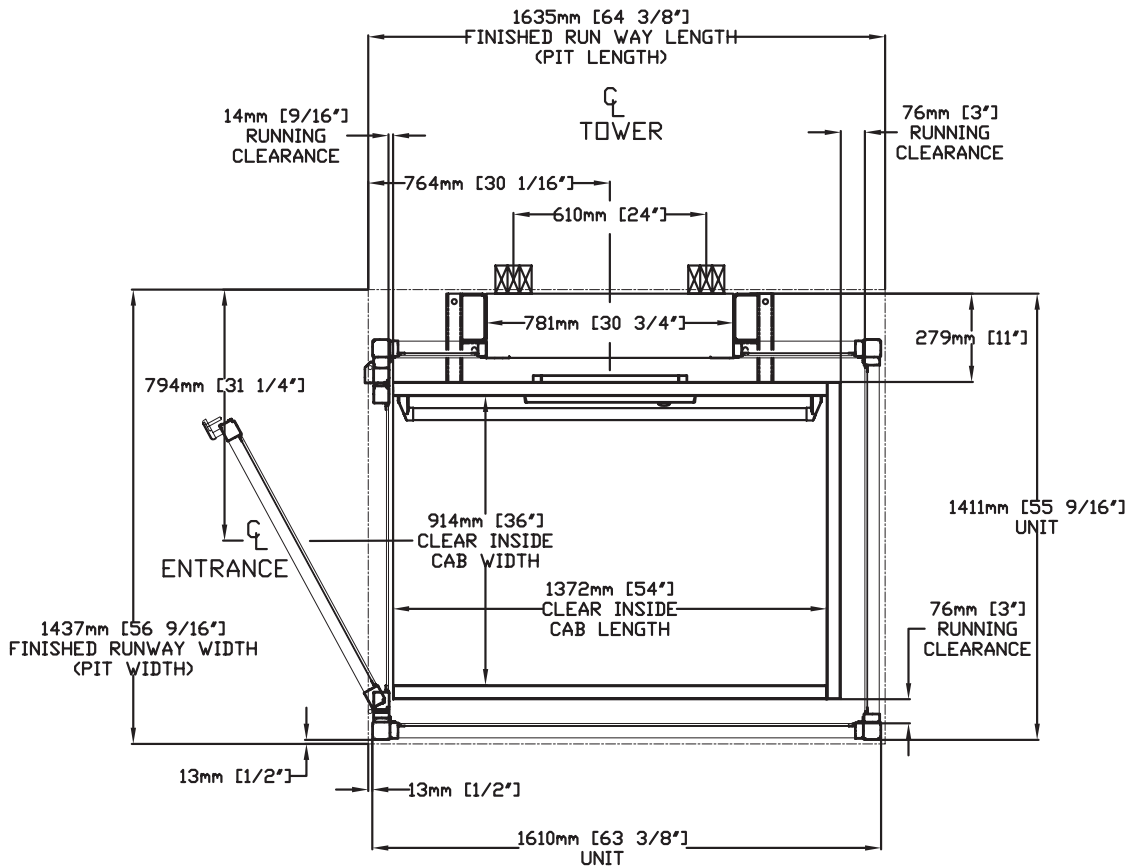

Figure 16: Plan View - Type 1L, 36" x 60" Cab, Hoistway Application

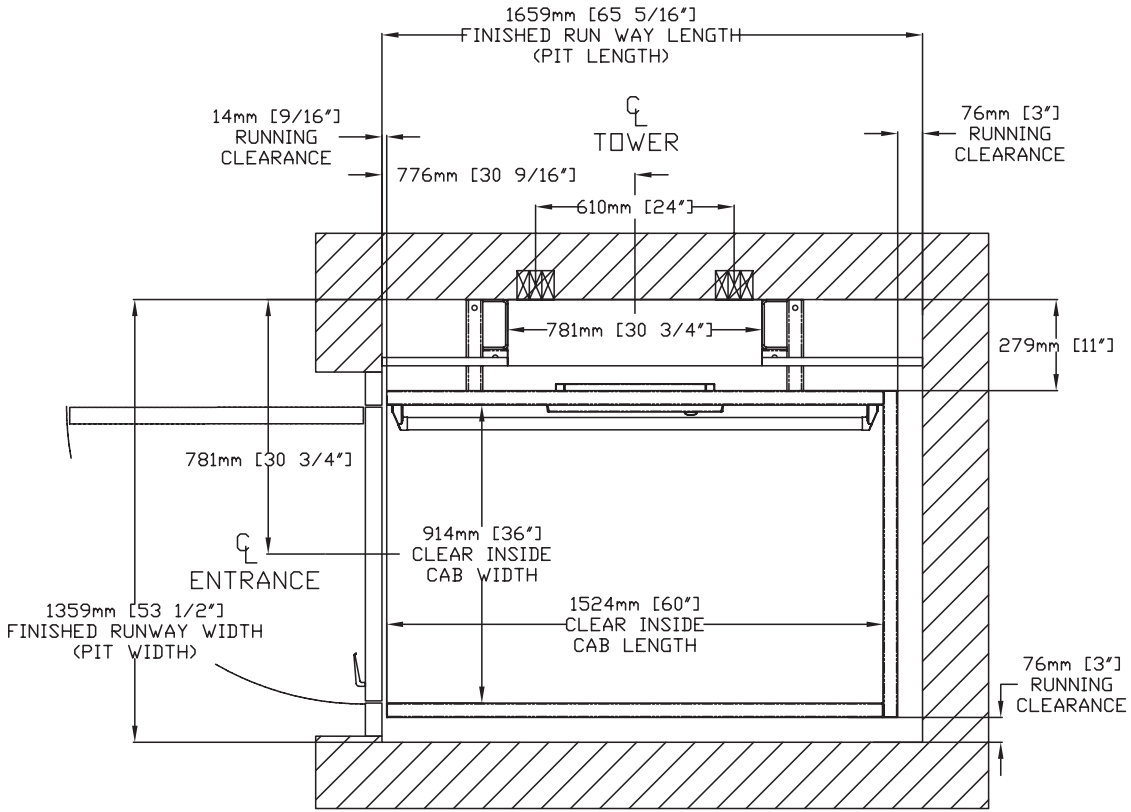

Figure 17: Plan View - Type 1L, 36" x 60" Cab, Enclosure Application

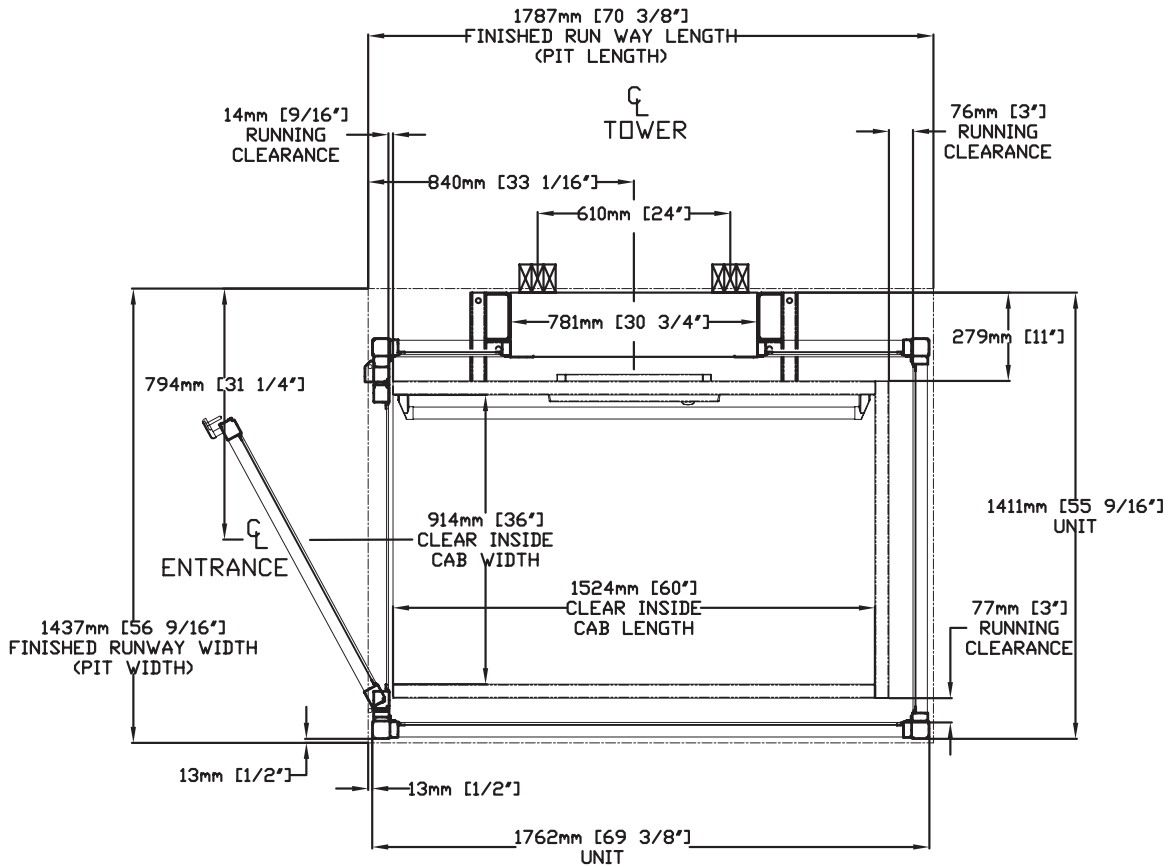

Figure 18: Plan View - Type 1R, 36" x 48" Cab, Hoistway Application

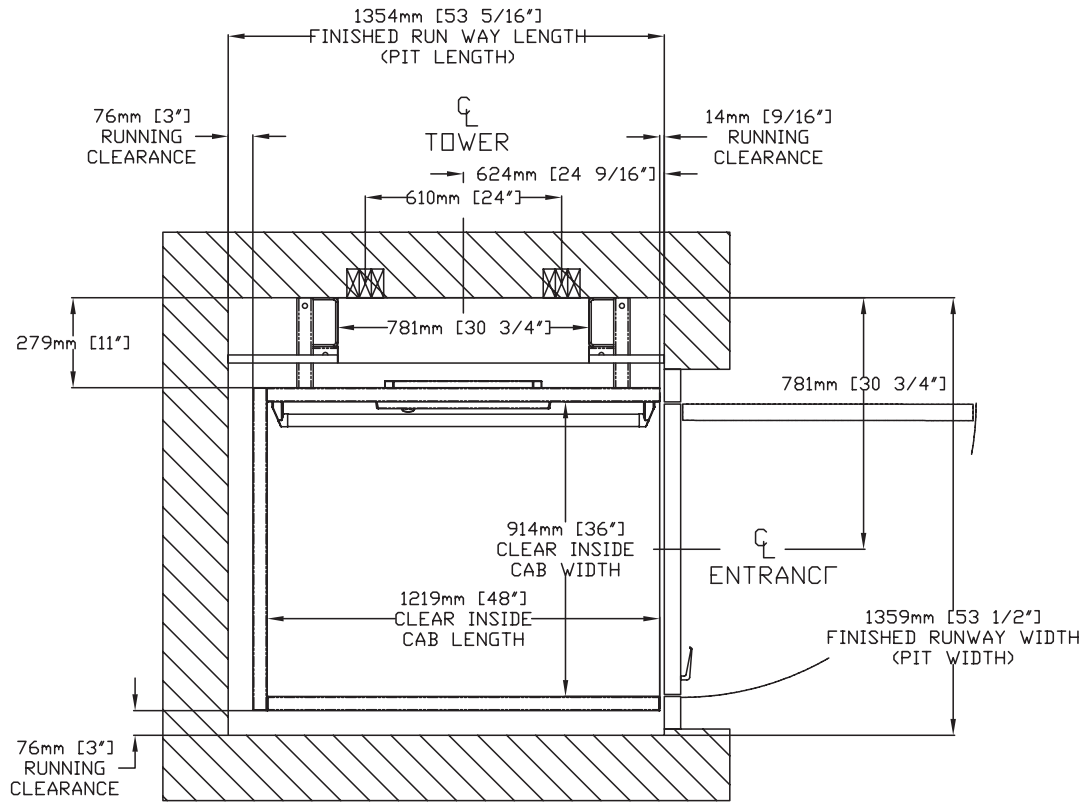

Figure 19: Plan View - Type 1R, 36" x 48" Cab, Enclosure Application

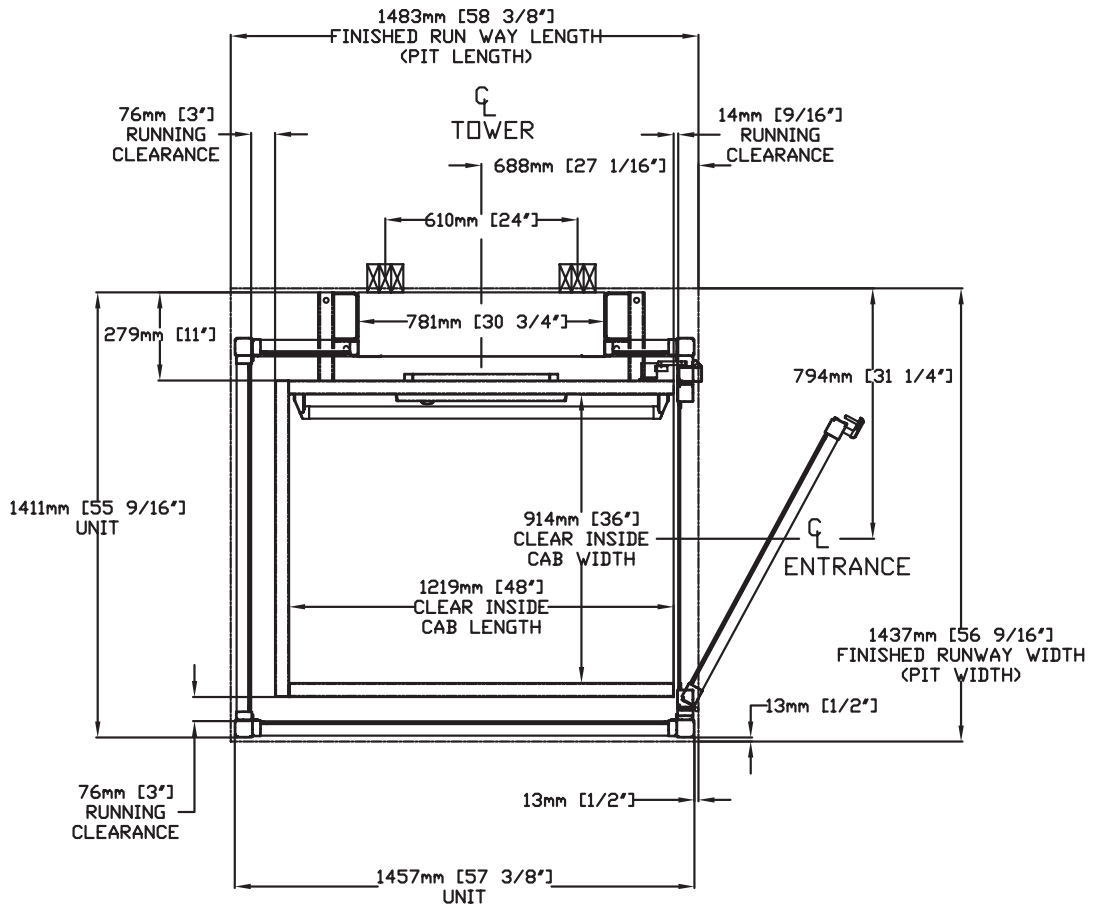

Figure 20: Plan View - Type 1R, 36" x 54" Cab, Hoistway Application

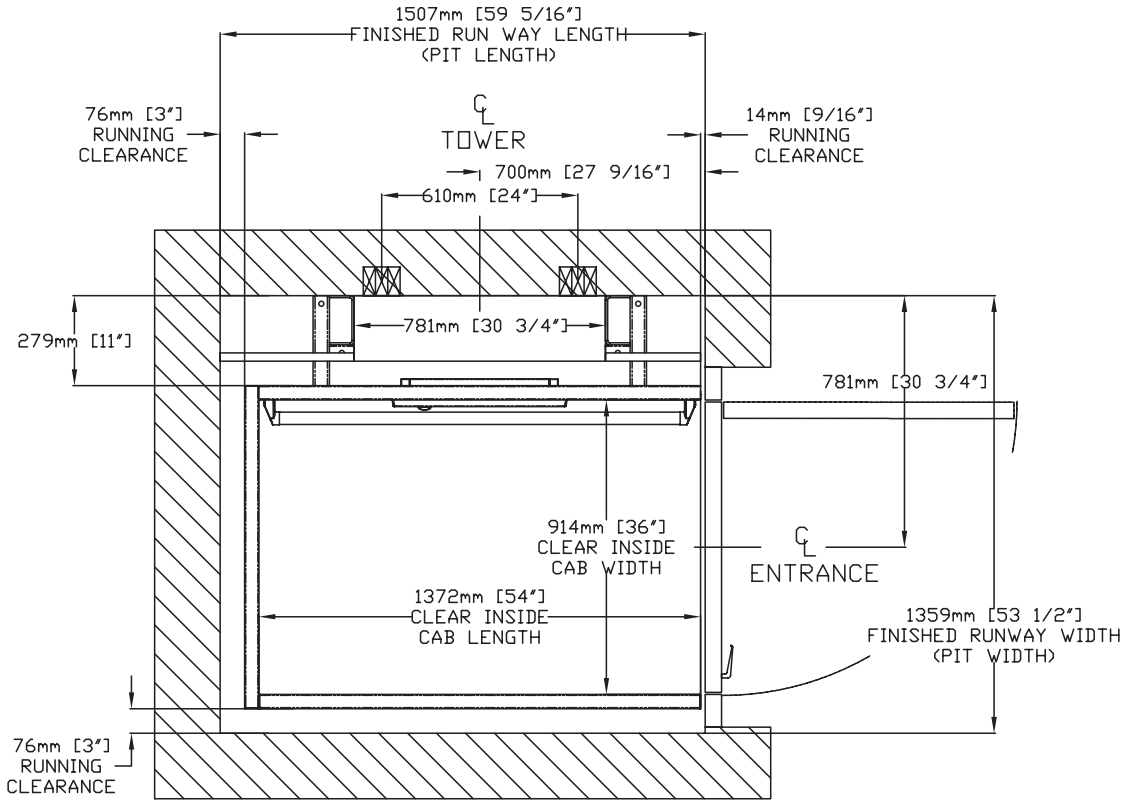

Figure 21: Plan View - Type 1R, 36" x 54" Cab, Enclosure Application

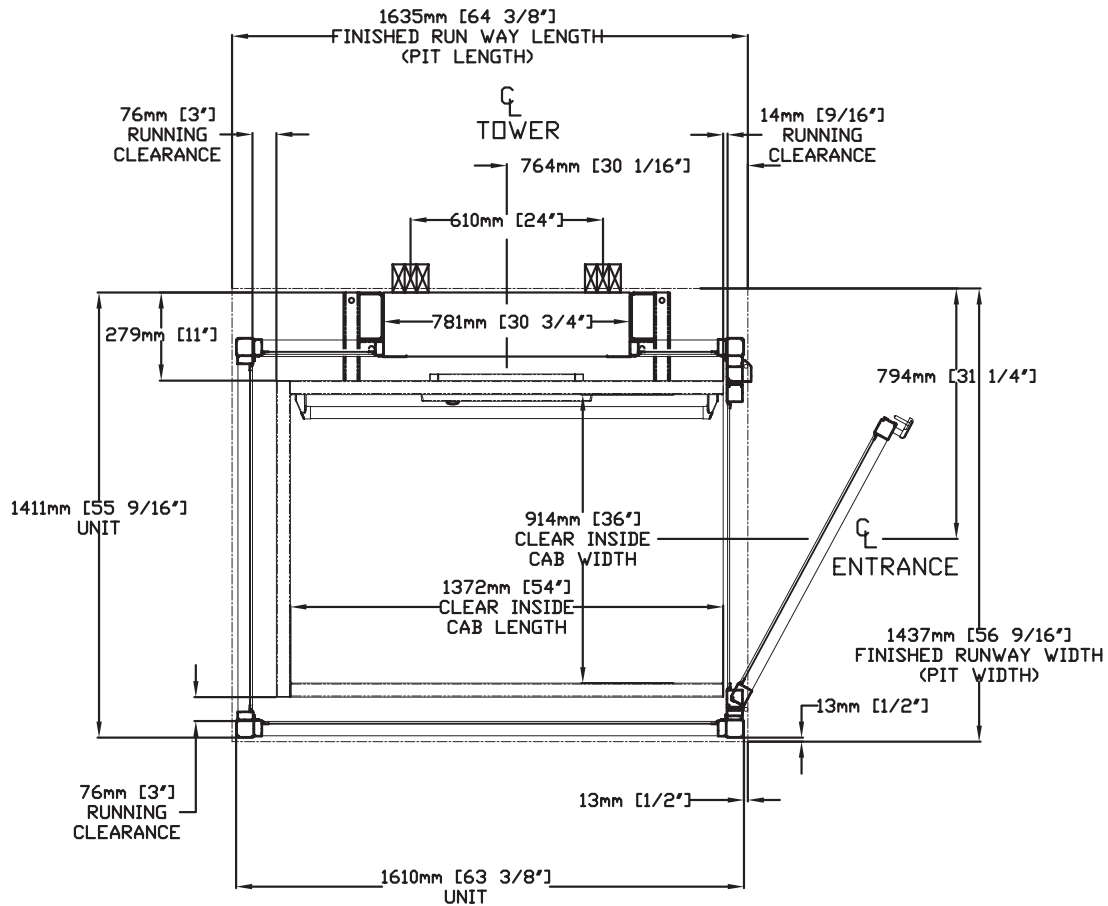

Figure 22: Plan View - Type 1R, 36" x 60" Cab, Hoistway Application

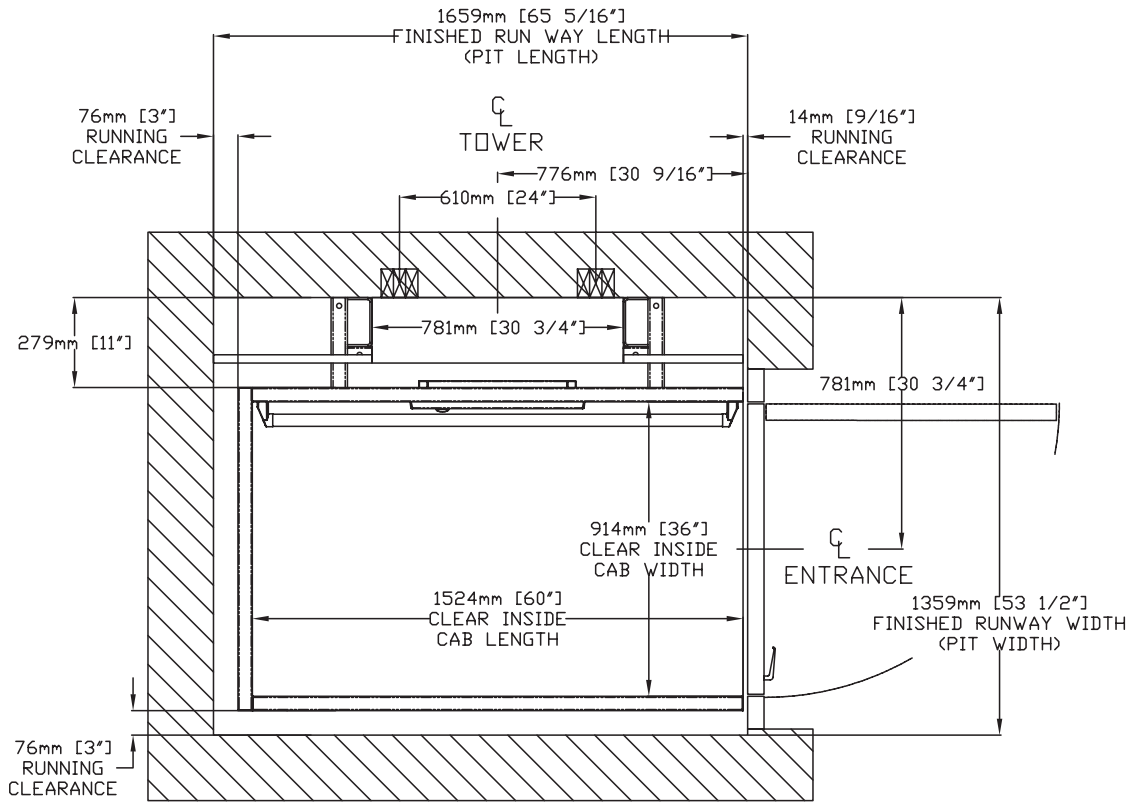

Figure 23: Plan View - Type 1R, 36" x 60" Cab, Enclosure Application

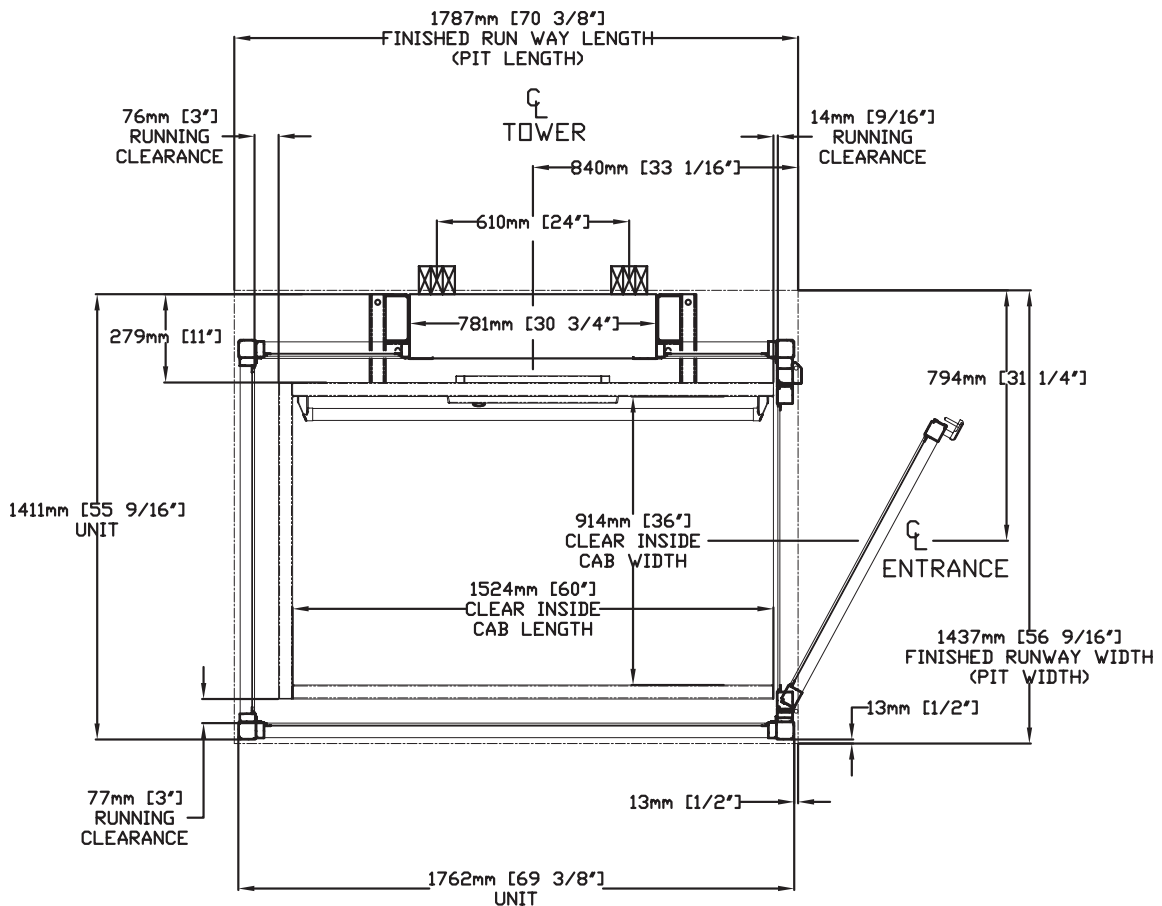

Figure 24: Plan View - Type 2, 36" x 48" Cab, Hoistway Application

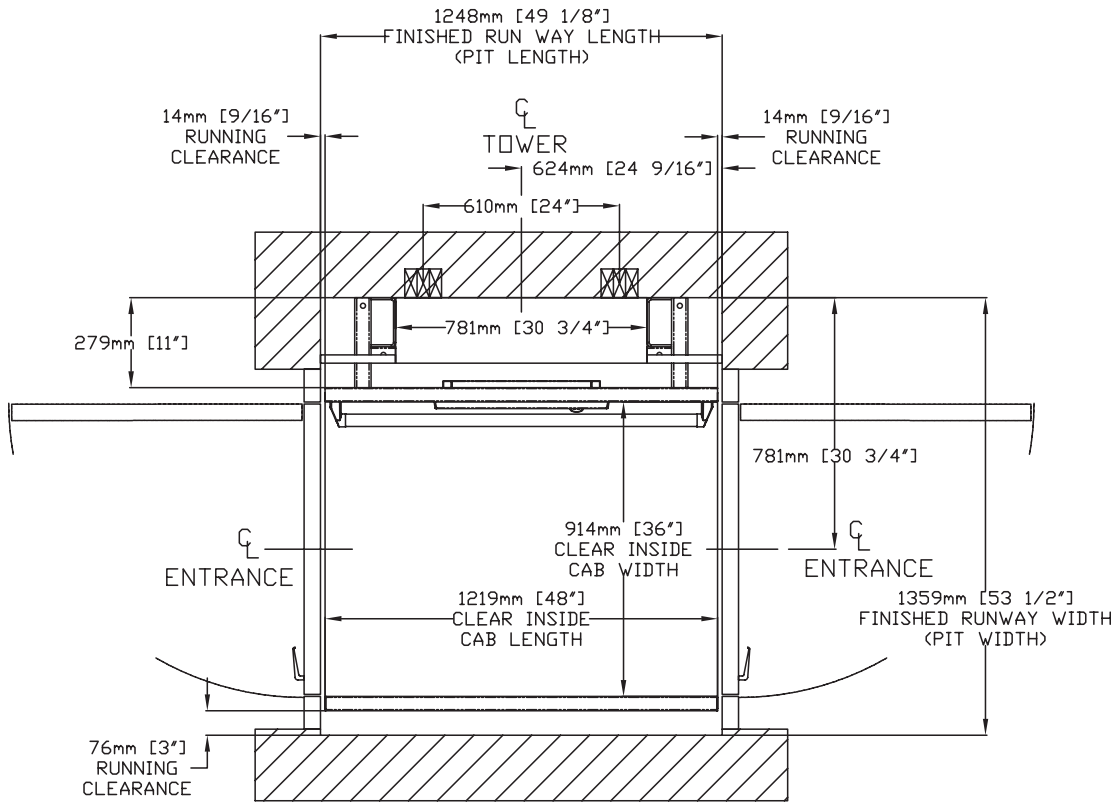

Figure 25: Plan View - Type 2, 36" x 48" Cab, Enclosure Application

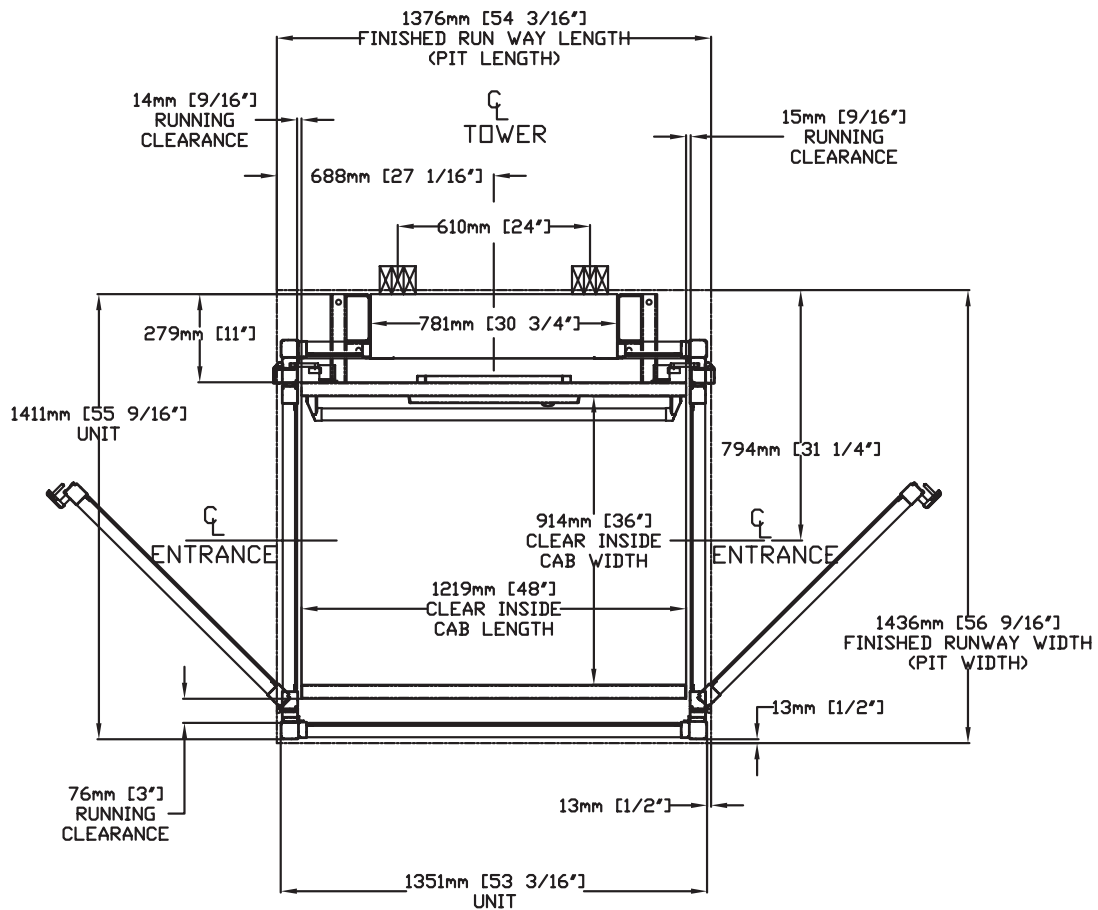

Figure 28: Plan View - Type 2, 36" x 60" Cab, Hoistway Application

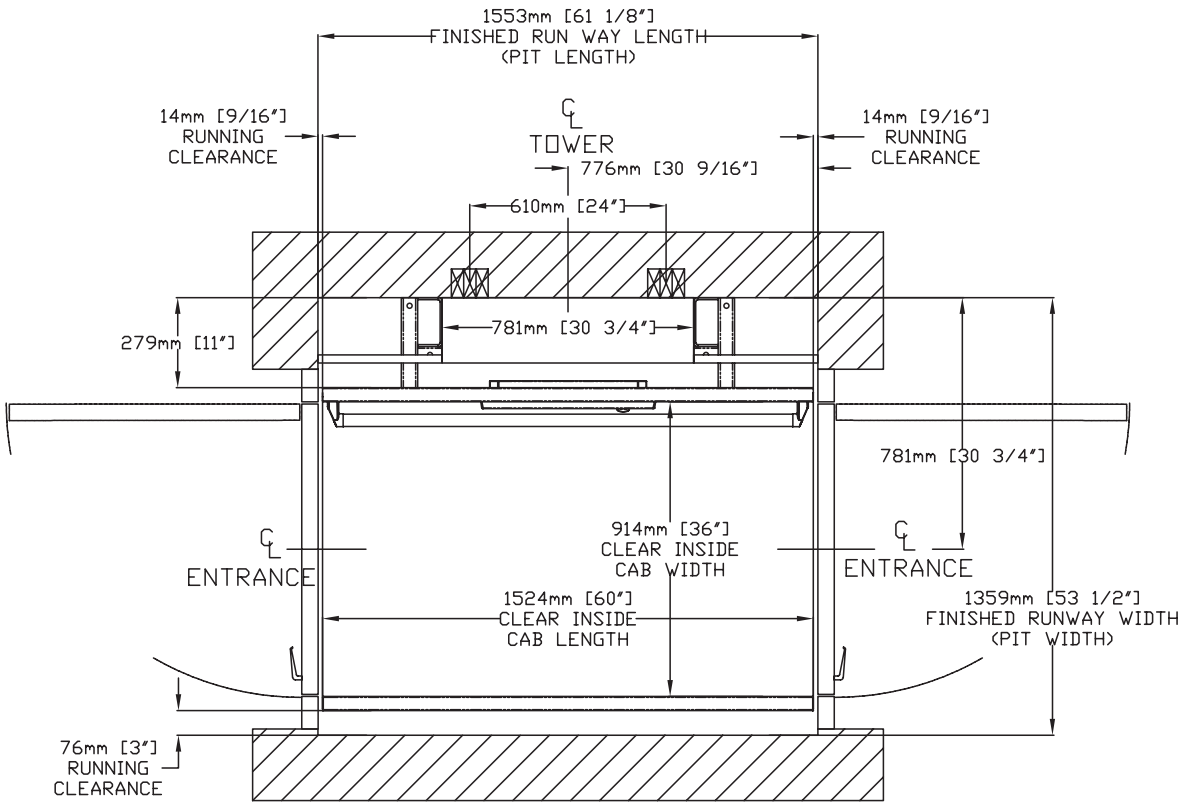

Figure 29: Plan View - Type 2, 36" x 60" Cab, Enclosure Application

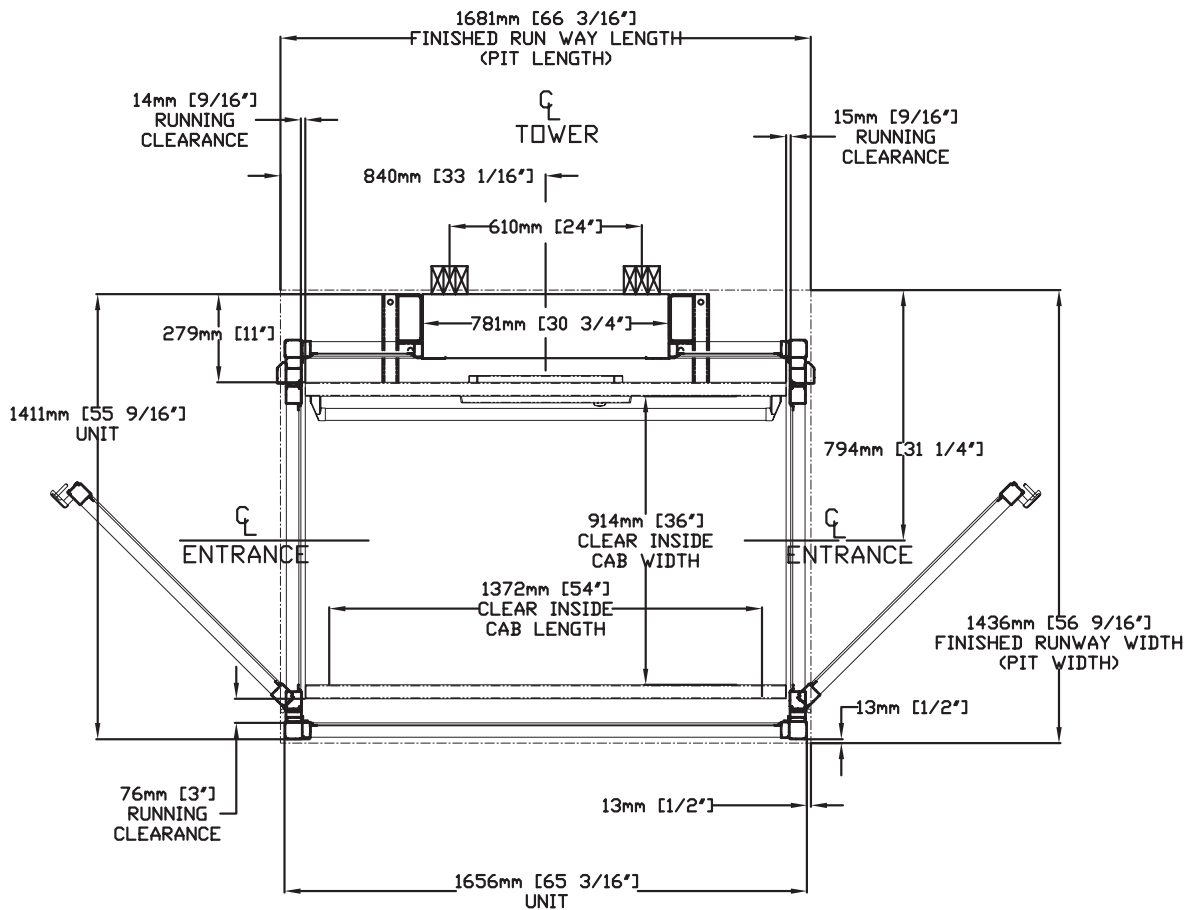

Figure 30: Plan View - Type 3, 36" x 48" Cab, Hoistway Application

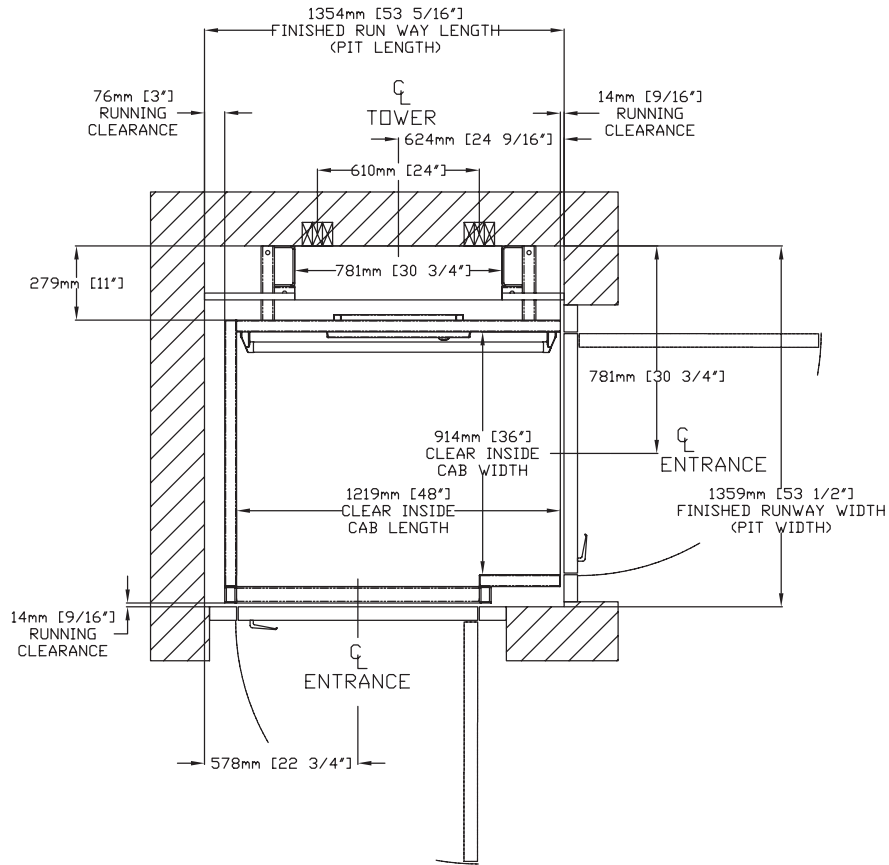

Figure 31: Plan View - Type 3, 36" x 48" Cab, Enclosure Application

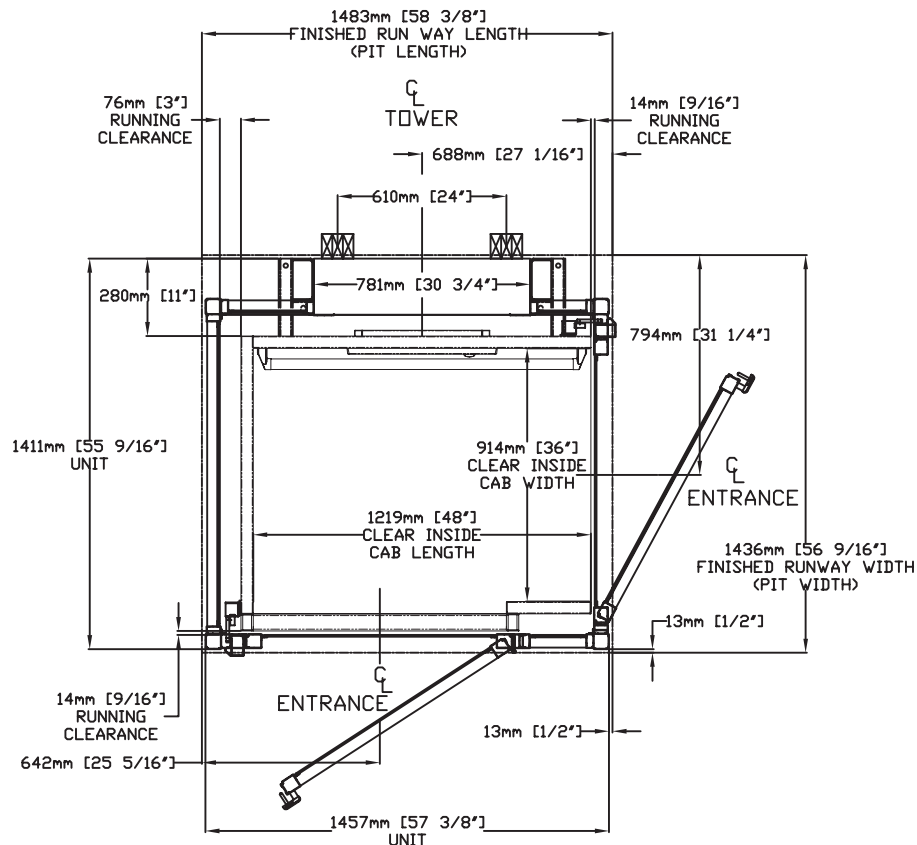

Figure 32: Plan View - Type 3, 36" x 54" Cab, Hoistway Application

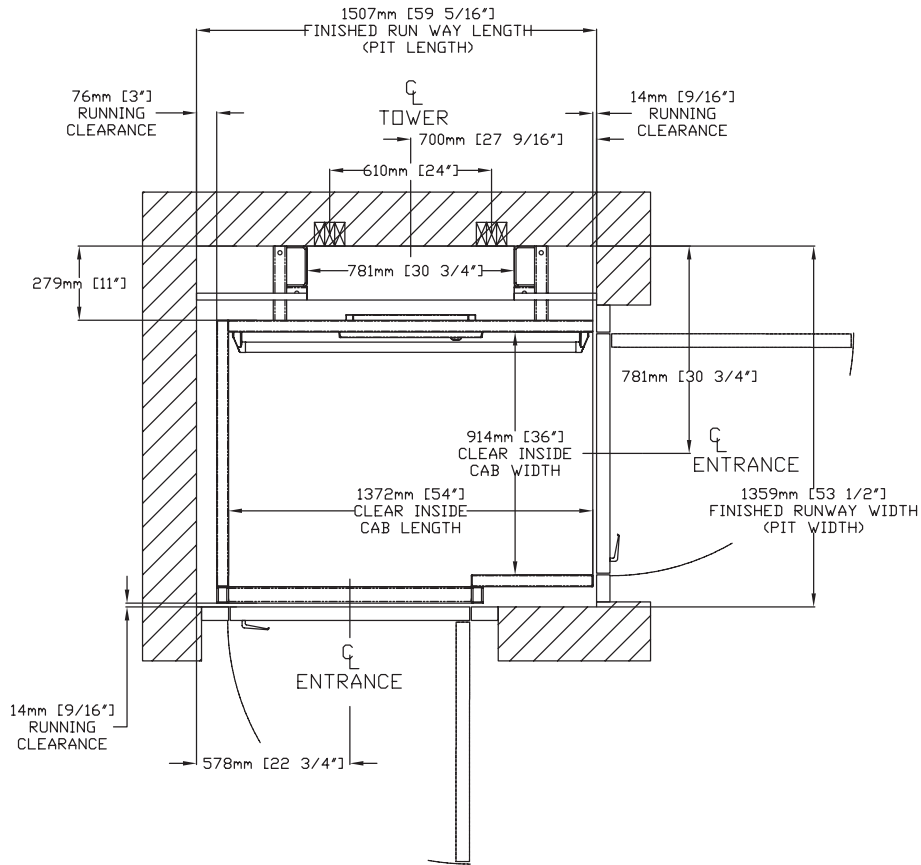

Figure 33: Plan View - Type 3, 36" x 54" Cab, Enclosure Application

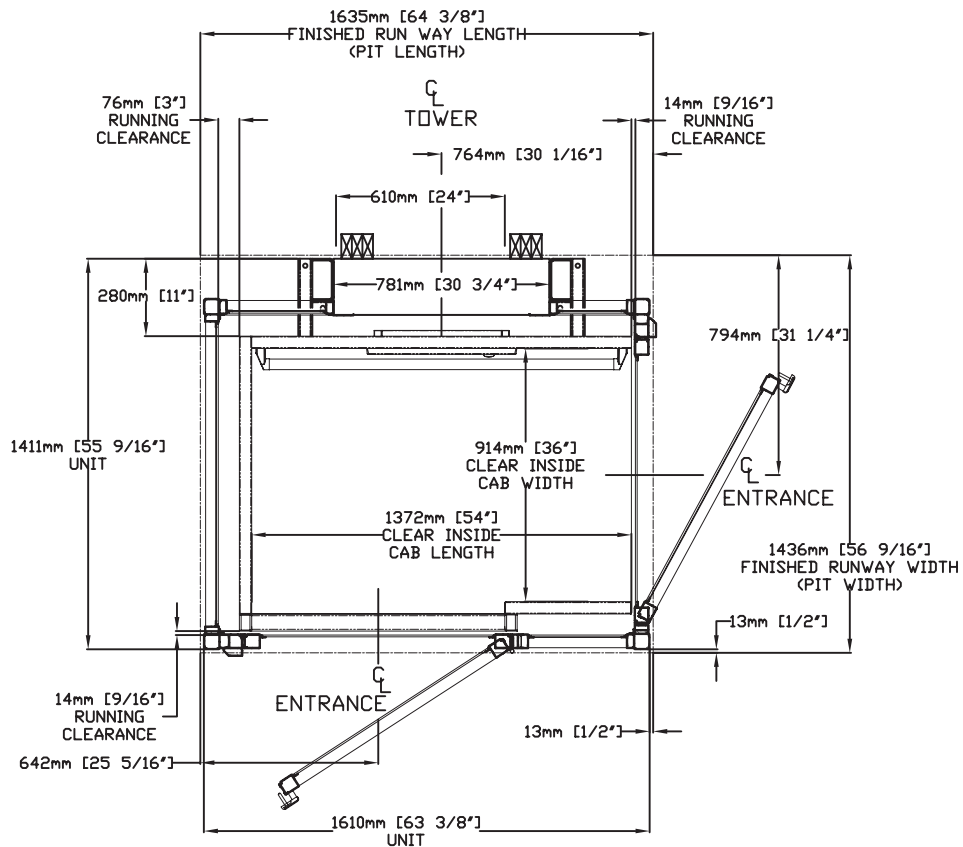

Figure 34: Plan View - Type 3, 36" x 60" Cab, Hoistway Application

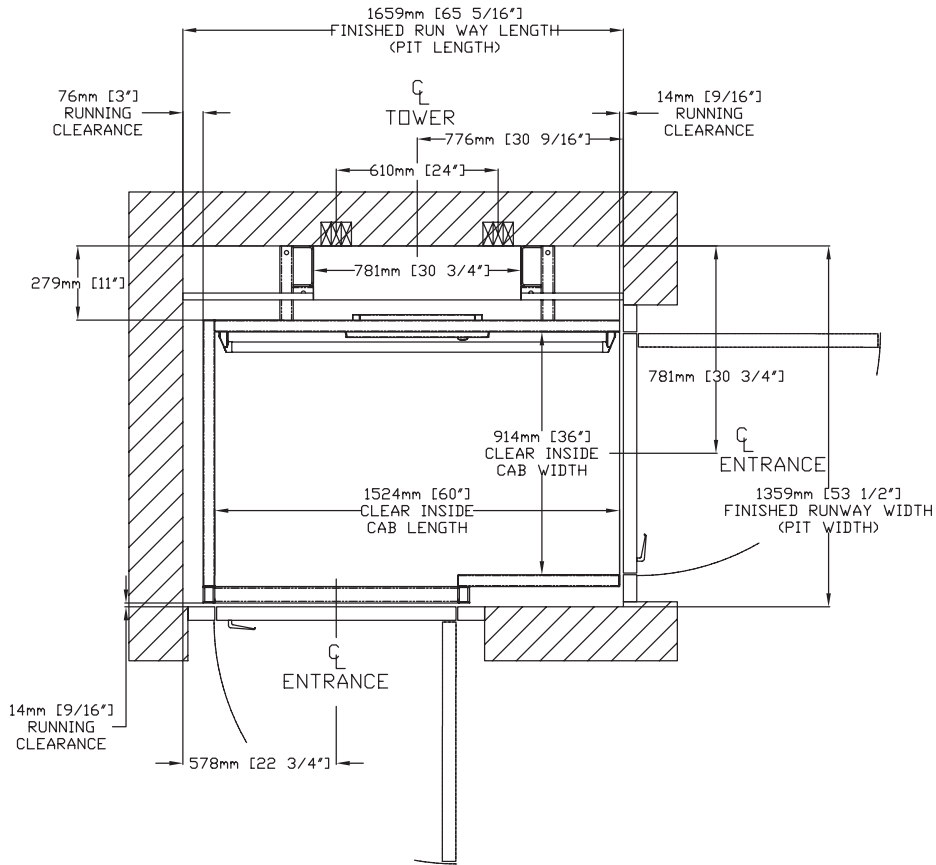

Figure 35: Plan View - Type 3, 36" x 60" Cab, Enclosure Application

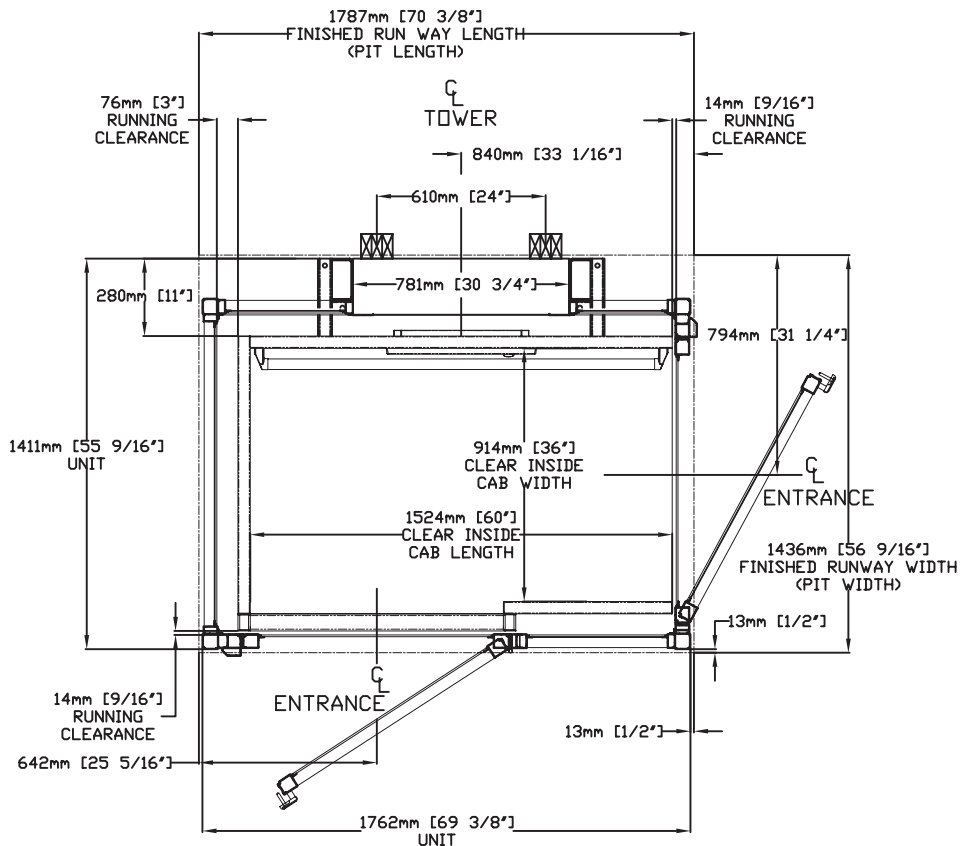

Figure 36: Plan View - Type 4, 36" x 48" Cab, Hoistway Application

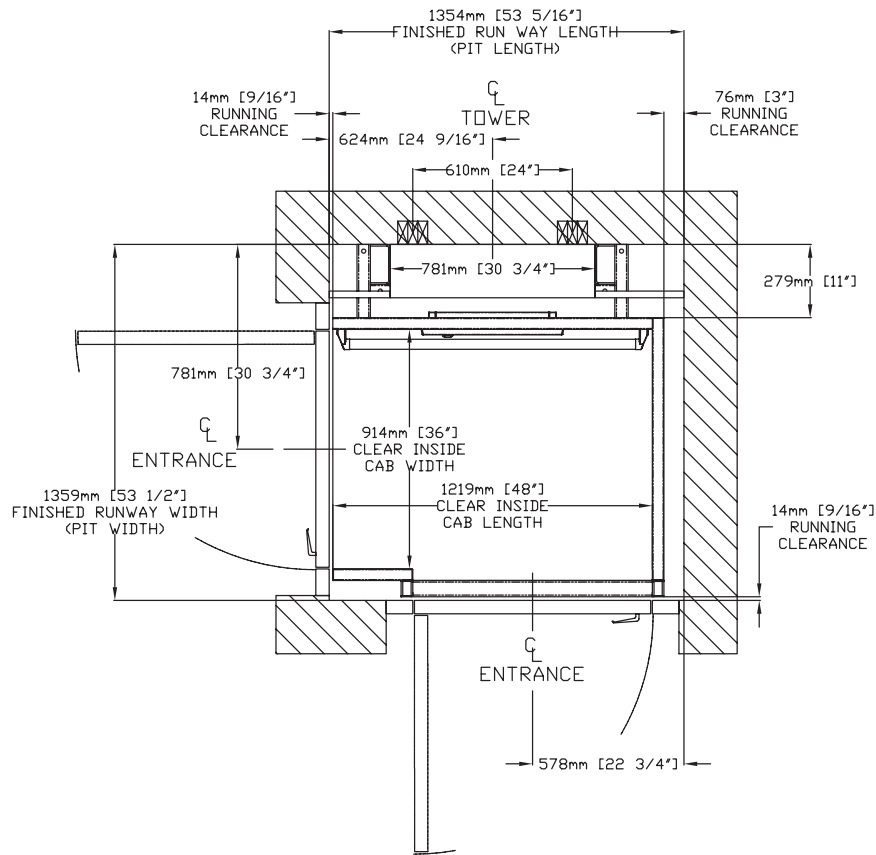

Figure 37: Plan View - Type 4, 36" x 48" Cab, Enclosure Application

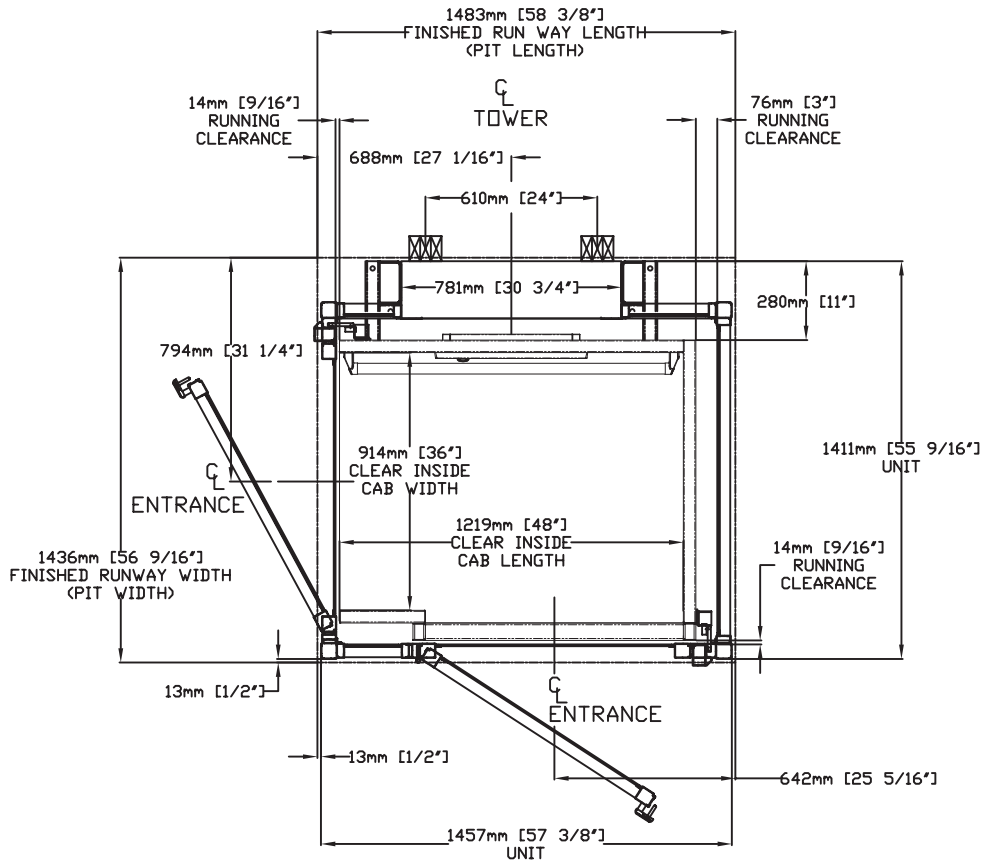

Figure 38: Plan View - Type 4, 36" x 54" Cab, Hoistway Application

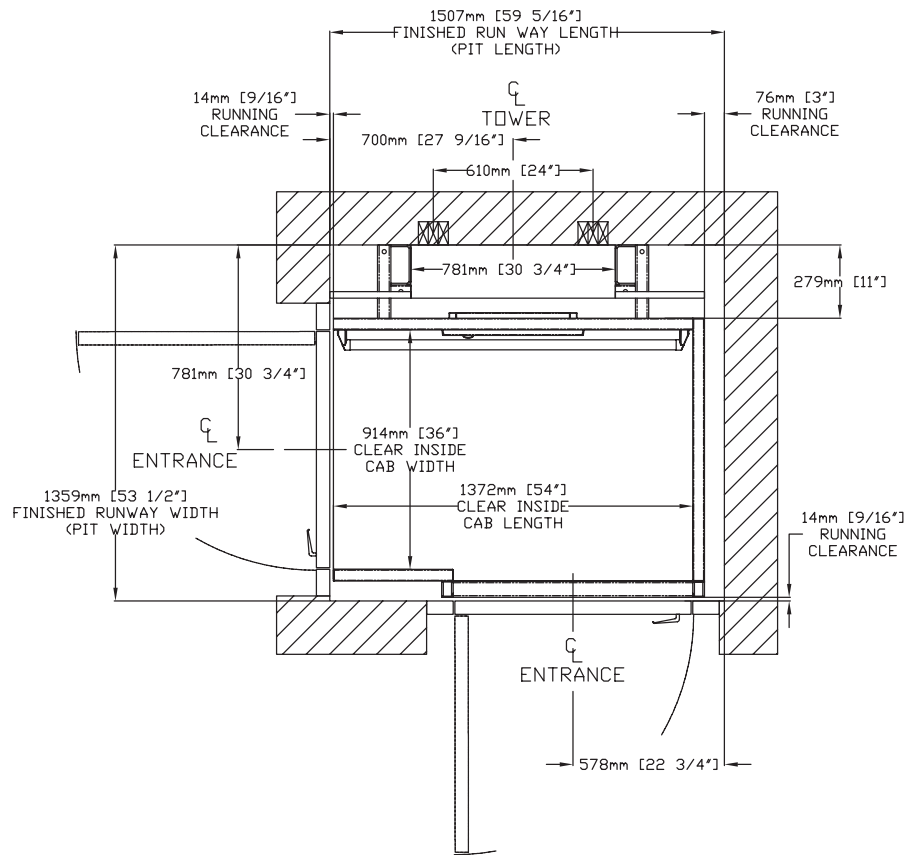

Figure 39: Plan View - Type 4, 36" x 54" Cab, Enclosure Application

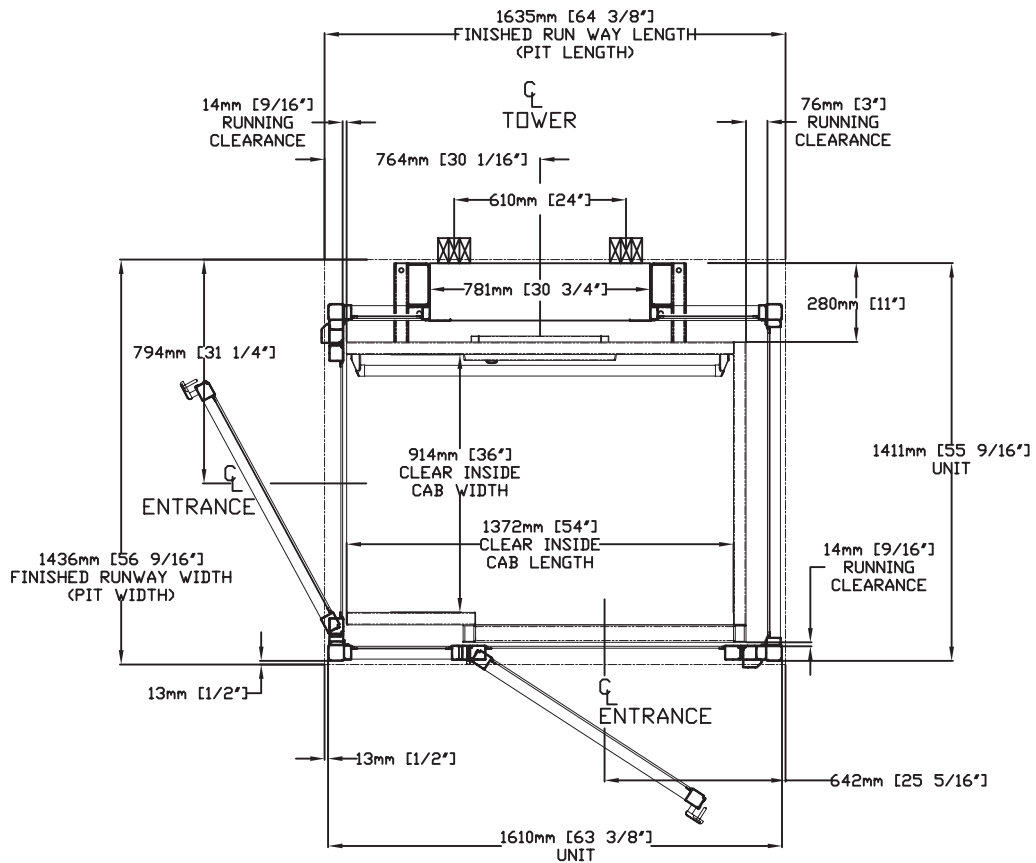

Figure 40: Plan View - Type 4, 36" x 60" Cab, Hoistway Application

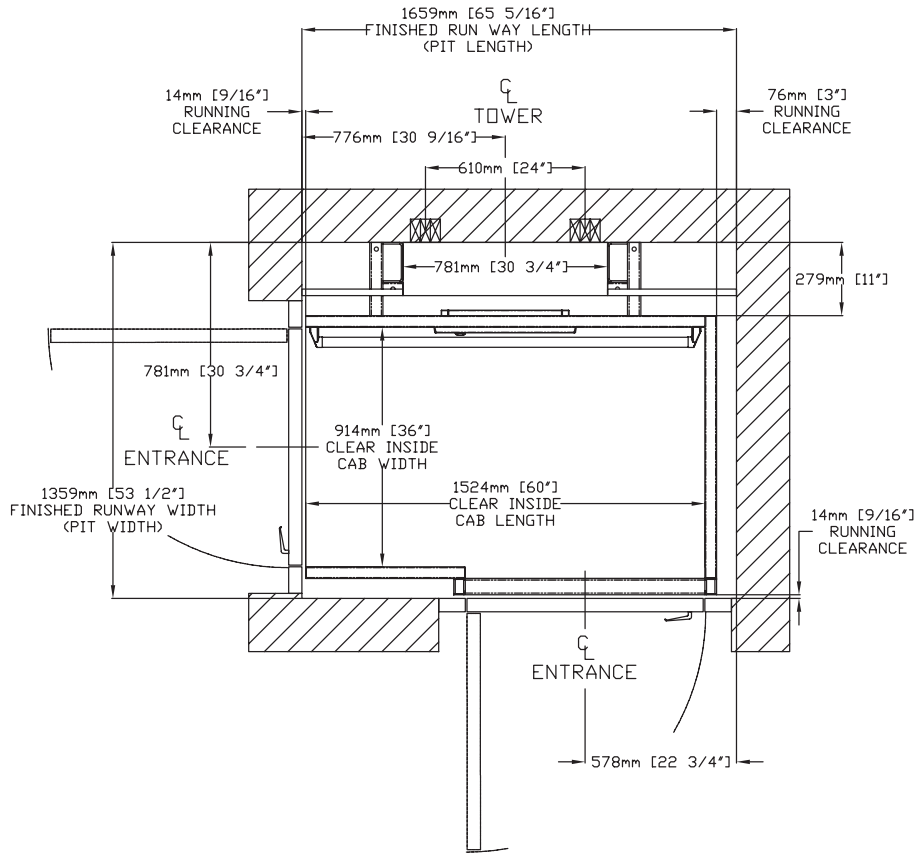

Figure 41: Plan View - Type 4, 36" x 60" Cab, Enclosure Application

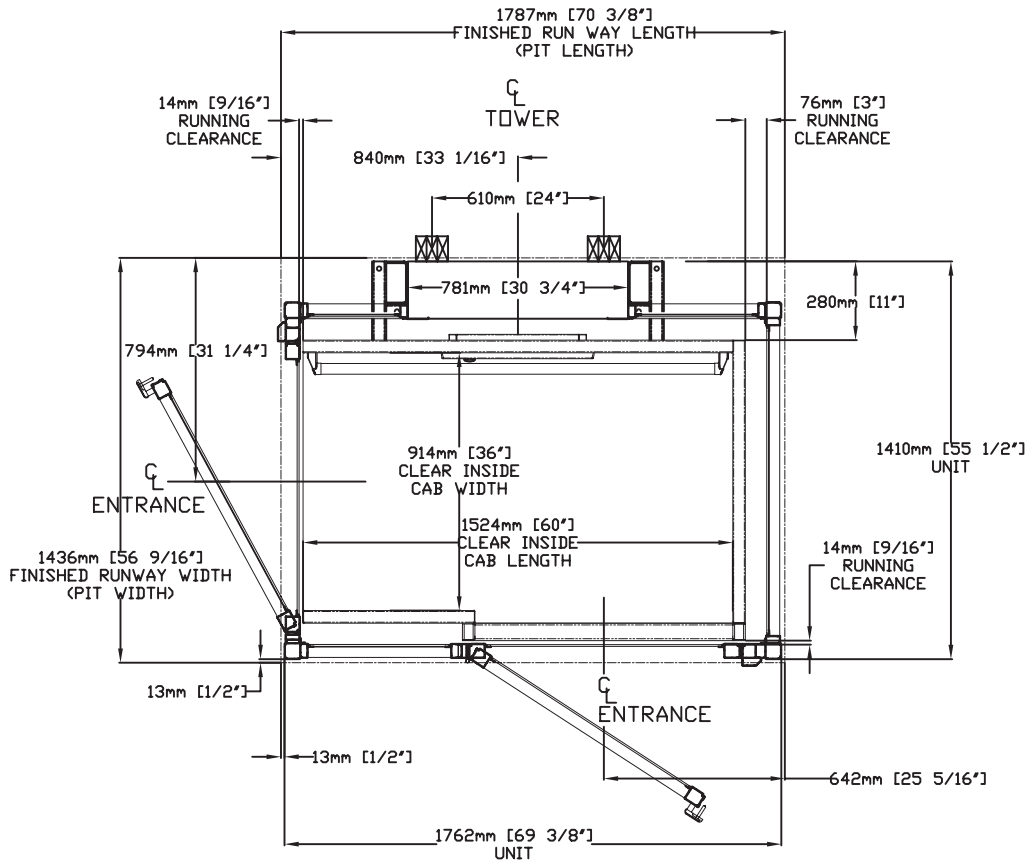
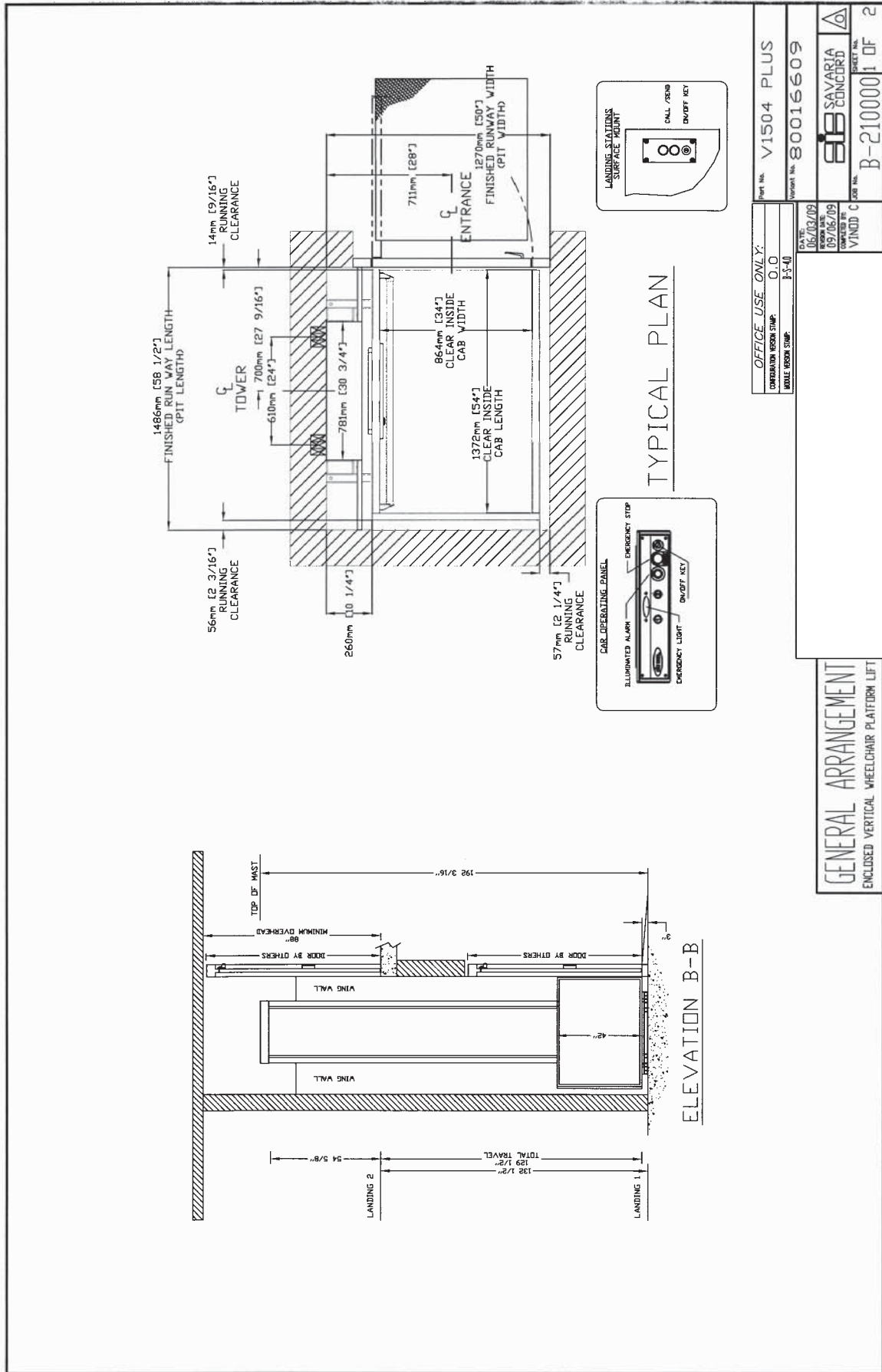

Figure 42: Sample Installation Drawings (Sheet 1) - Hoistway Application



OFFICE USE ONLY:	Sheet No. V1504 PLUS
OPERATION ROOM STAMP:	Project No. 80016609
MODEL ROOM STAMP:	DATE: 06/03/09
	DATE: 09/06/09
	DESIGNED BY: SAVARIA
	CONTRACT NO: VINDO C
	PROJECT NO: B-2100001
	SHEET NO: 1 OF 2

GENERAL ARRANGEMENT
ENCLOSED VERTICAL WHEELCHAIR PLATFORM LIFT

Figure 43: Sample Installation Drawings (Sheet 2) - Hoistway Application

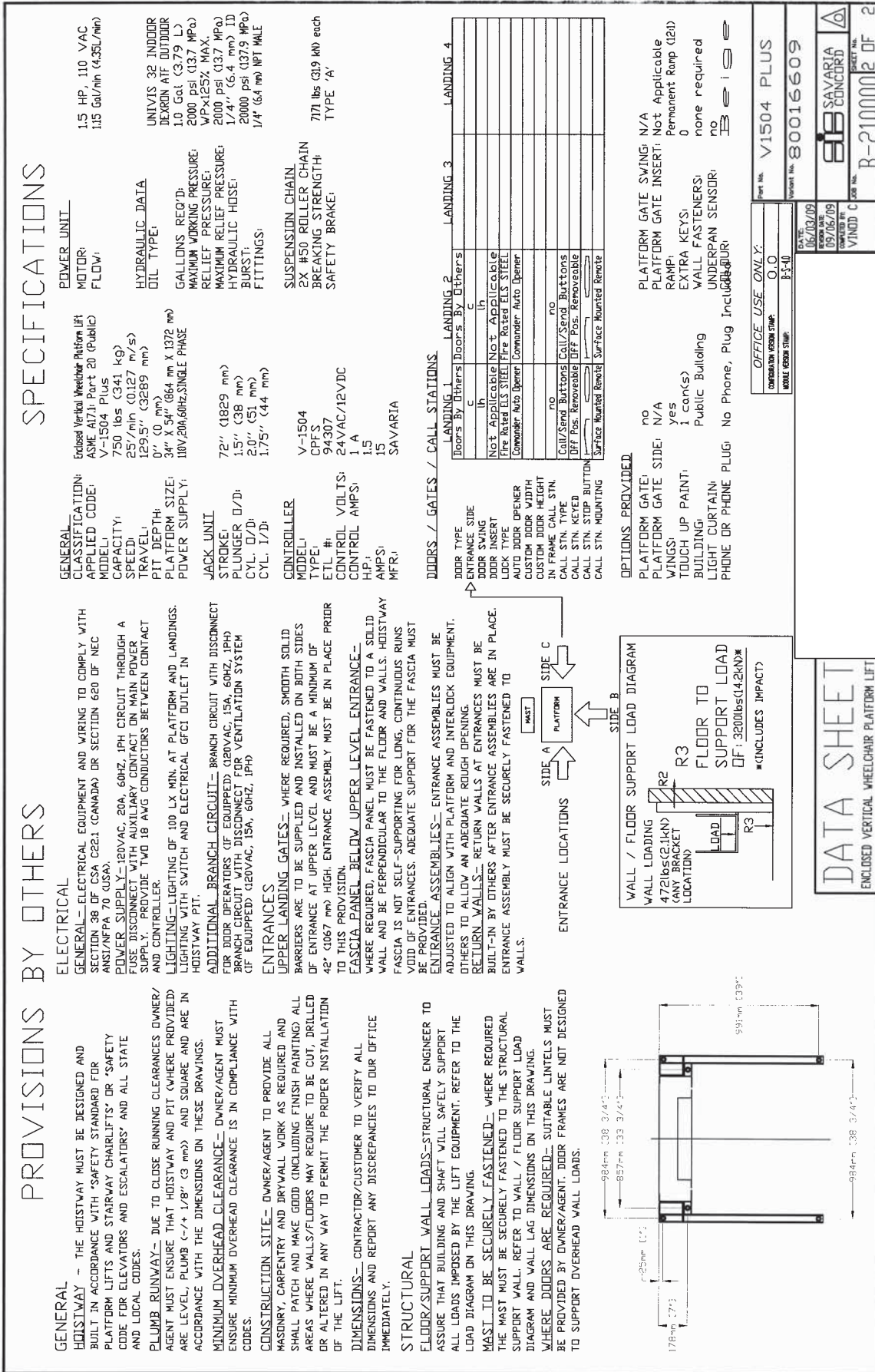

PROVISIONS BY OTHERS

GENERAL REQUIREMENTS

Hoistway

The hoistway must be designed and built in accordance with the “safety standard for platform lifts and stairway chairlifts” or the “safety code for elevators and escalators” and all state and local codes.

Plumb Runway

Due to close running clearances, the owner/agent must ensure that the hoistway and the pit (where provided) are level, plumb and square and are in accordance with the dimensions on the installation drawings.

Minimum Overhead Clearance

The owner/agent must ensure the minimum overhead clearance is in compliance with codes.

Construction Site

The owner/agent is required to provide all masonry, carpentry and drywall work as required and shall patch and make good (including finish painting) all areas where walls/floors may need to be cut, drilled or altered in any way to permit the proper installation of the lift.

Dimensions

The contractor/customer is required to verify all dimensions and report any discrepancies to our office immediately.

STRUCTURAL REQUIREMENTS

Floor/Support Wall Loads

The structural engineer is to ensure that the building and shaft will safely support all loads imposed by the lift equipment. Refer to the installation drawings for the loads imposed by the equipment.

Mast to be Securely Fastened

Where required, the mast must be securely fastened to the structural support wall. Refer to the installation drawings for the loads imposed by the equipment.

Where Doors are Required

Suitable lintels must be provided by the owner/agent. Door frames are not designed to support overhead wall loads.

ELECTRICAL REQUIREMENTS

General

Electrical equipment and wiring must comply with Section 38 of CSA C22.1 (Canada) or Section 620 of NEC ANSI NFPA 70 (USA).

Power Supply

A 120 VAC, 20A, 60 Hz, single-phase circuit through a fused disconnect with an auxiliary contact on the main power supply is required.

Lighting

Lighting of 100 lux minimum is required at platforms and landings. Lighting with a switch and electrical GFCI outlet is required in the hoistway pit.

Additional Branch Circuit

A 120 VAC, 15A, single-phase, 60 Hz branch circuit with a disconnect for the door operators (if equipped) is required. A 120 VAC, 15A, single-phase, 60 Hz branch circuit with a disconnect for the ventilation system (if equipped) is required.

ENTRANCE REQUIREMENTS

Upper Landing Gates

Where required, smooth solid barriers are to be supplied and installed on both sides of the entrance at the upper level and must be a minimum of 42" (1067 mm) high. The entrance assembly must be in place prior to this provision.

Fascia Panel Below Upper Level Entrance

Where required, fascia panel must be fastened to a solid wall and be perpendicular to the floor and walls. Hoistway fascia is not self-supporting for long, continuous runs void of entrances. Adequate support for the fascia must be provided.

Entrance Assemblies

Entrance assemblies must be adjusted to align with the platform and interlock equipment. Others must allow an adequate opening.

Return Walls

Return walls at the entrances must be built-in by others after the entrance assemblies are in place. The entrance assembly must be securely fastened to the walls by the contractor.

Architect Specifications

V1504-STD

SECTION 14202 ELEVATORS AND LIFTS

PART 1 GENERAL

1.1 SECTION INCLUDES

- A. Vertical platform lifts.

1.2 RELATED SECTIONS

- A. Division 16 Sections for electrical service for elevators to and including disconnect and fused switches at machine room.
- B. Division 16 Sections for standby power source, transfer switch, and connection from auxiliary contacts in transfer switch to controller.
- C. Division 16 Section "Voice and Data Communication Cabling" for telephone service to elevators.

1.3 REFERENCES

- A. American National Standards Institute (ANSI) B-29.2 - Chain Standards for Inverted Tooth (Silent) Chains and Sprockets.
- B. American Society of Mechanical Engineers (ASME) A17.1 - Safety Code for Elevators and Escalators.
- C. American Society of Mechanical Engineers (ASME) A18.1 - Safety Standard for Platform and Stairway Chair Lifts.
- D. U.S. Architectural & Transportation Barriers Compliance Board's "Americans with Disabilities Act (ADA), Accessibility Guidelines for Buildings and Facilities (ADAAG)".

1.4 REQUIREMENTS OF REGULATORY AGENCIES:

- A. Fabrication and installation work in compliance with applicable jurisdictional authorities.
- B. File shop drawings and submissions with local authorities as the information is made available. Company pre-inspection and jurisdictional authority inspections and permits are to be made on timely basis as required.

1.5 SUBMITTALS

- A. Submit under provisions of Section 01300.
- B. Product Data: Manufacturer's data sheets on each product to be used, including:
 - 1. Preparation instructions and recommendations.
 - 2. Storage and handling requirements and recommendations.
 - 3. Installation methods.
- C. Shop Drawings: Provide a complete layout of lift equipment detailing dimensions and clearances as required.
- D. Selection Samples: For each finish product specified requiring selection of color or finish, two complete sets of color charts representing manufacturer's full range of available colors and patterns.

1.6 QUALITY ASSURANCE

- A. Manufacturer Qualifications:
- B. Installer Qualifications:
 - 1. Execute work of this section only by a company that has adequate product liability insurance.
 - 2. Skilled tradesmen shall be employees of the installing contractor approved by the manufacturer, with demonstrated ability to perform the work on a timely basis.

1.7 DELIVERY, STORAGE, AND HANDLING

- A. Store products in manufacturer's unopened packaging until ready for installation.
- B. Store and dispose of solvent-based materials, and materials used with solvent-based materials, in accordance with requirements of local authorities having jurisdiction.

1.8 PROJECT CONDITIONS

- A. Maintain environmental conditions (temperature, humidity, and ventilation) within limits recommended by manufacturer for optimum results. Do not install systems under environmental conditions outside manufacturer's absolute limits.

1.9 WARRANTY

- A. Coverage - this warranty applies to the repair or replacement, at Manufacturer's option, of parts that fail due to defective material or workmanship. Manufacturer may, at its option, provide factory reconditioned parts. This warranty is provided to the Authorized Dealer on behalf of the final purchaser of the product and is not transferable. The Manufacturer's warranty does not cover labor charges for the removal, repair or replacement of warranty parts but such costs may be covered for a period of time by Authorized Dealer's warranty, which is provided to purchaser separately.
 - 1. The manufacturer shall offer a 36-month warranty on parts from date of substantial completion.

PART 2 PRODUCTS

2.1 MANUFACTURERS

- A. Acceptable Manufacturer: Savaria Concord Lifts Inc., which is located at: 107 Alfred Kuehne Blvd. ; Brampton, ON, Canada L6T 4K3; Toll Free Tel: 800-661-5112; Tel: 905-791-5555; Email: [request info \(info@concordelevator.com\)](mailto:info@concordelevator.com); Web: www.concordelevator.com
- B. Requests for substitutions will be considered in accordance with provisions of Section 01600.

2.2 HYDRAULIC VERTICAL PLATFORM LIFT

- A. Hydraulic Vertical Platform Lifts: Savaria Model V1504-STD.
- B. Hydraulic Vertical Platform Lift: The lift described here, manufactured by Savaria Concord Lifts Inc., is a vertical platform lift consisting of a hydraulic tower with a lifting platform. The platform can be customized to better accommodate a wheelchair user or a person with impaired

- mobility. The lift can be used indoor or outdoor (with optional package) and in commercial or residential applications.
- C. Work described in this section includes providing equipment, incidental material and labor required for complete, operable hydraulic platform lift installation. Lifts shall be erected, installed, adjusted, tested and placed in operation by lift system manufacturer, or manufacturer's authorized installer.
1. Lifts shall be in accordance with the ASME A18. 1 and ADA compliant including local codes and regulations except where specified otherwise.
- D. The following preparatory work to receive the lifts specified in this section is part of the work of other sections:
1. Permanent 120 VAC, 20 amp single phase power to operate lift to be provided from a lockable fused/cartridge type disconnect switch with auxiliary contacts for battery operation. Refer to drawings for permanent power specifications and location of disconnects. Temporary power may be provided to expedite installation of lift.
 2. Provide a plumb and square hoistway with smooth interior surfaces, including fascias or furring of the hoistway interior.
 3. Provide rough openings per lift contractor's shop drawings.
 4. Provide substantial, level pit floor slab as indicated on the lift contractor's shop drawings.
- E. Characteristics:
1. Rated Load: 750 lb (340 kg).
 2. Rated Speed: 25 fpm (0.13 m/s).
 3. Usable Car Dimensions: 34 inches by 54 inches (864 mm by 1372 mm).
 4. Levels Serviced: 2.
 5. Number of Openings: 2.
 6. Car Access: Enter/Exit same side.
 7. Max. Travel: 23 feet in Canada, 14 feet in USA. Refer to drawings.
 8. Operations: Constant pressure.
 9. Power Supply: 110 volt, 15 amp, 1 phase, 60 Hz.
 10. Drive System: 2:1 Roller chain hydraulic.
 11. Paint: Powder coat finish.
 12. Emergency Power: Battery operation in down direction.
 13. Controller: Electronic-free relay logic.
 14. Motor/Pump: 110VAC, 1.5HP.
 15. Manual Lowering: Outside the hoistway at desired landing.
 16. Color: Almond beige.
- F. Car Enclosure:
1. Side guards of platform shall have a steel frame with a powder coat finish and steel panel inserts to a minimum of 42 inches (1067 mm) above the upper landing.
 2. No platform gate required, to allow for ease of operation.
 3. Upper gate shall be 42 inches high by 36 inches wide (1067 mm by 914 mm), with metal or plexiglass inserts and shall be equipped with interlock, spring hinges and kick plate. Lower door shall be 80 inches high by 36 inches wide (2032 mm by 914 mm), with metal or plexiglass inserts and shall be equipped with interlock, hydraulic closer and kick plate on both sides. The inside kick plate shall be made of steel.
 4. Upper door shall be 36 inches wide by 80 inches high (914 mm by 2032 mm) top landing door instead of the top landing gate.
 5. Lower and upper door and door frame with 1 1/2 hour ULC Fire rating, heavy duty hinges, Door vision panel, flush mounting of door inside the hoistway and adjustable hydraulic door closer on door frame
 6. Doors and gates shall be flush mounted inside the hoistway as to avoid pinch points and shear hazards.
 7. Handrail: A single handrail, with 1-1/2 inches (38 mm) diameter rail and with both ends returned to the side guard, shall be located on the control wall of the carriage.
- G. Car Operation:
1. Car Operating Panel shall consist of constant pressure buttons or rocker switches, emergency stop/alarm button, on/off key switch and emergency light mounted on a removable stainless steel panel (Type 304 #4 Stainless Steel Finish).
 2. Emergency Operation The car shall be equipped with a battery operated light fixture, emergency battery lowering device and alarm in case of normal building supply failure. The battery shall be the rechargeable type with an automatic recharging system. A manual lowering device shall be located outside the hoistway in a lockable box positioned at a designated landing.
- H. Pumping Unit and Control:
1. The pumping unit and control shall be enclosed in the tower. The controller and pump unit shall be pre-wired and tested prior to shipment. The controller is to be electronic-free with relay logic operation for ease of maintenance and service. Pump unit shall incorporate the following features :
 2. Smooth stops at each landing.
 3. Adjustable pressure relief valve.
 4. Manually operable down valve to lower lift in the event of an emergency. This valve shall be activated from outside of the hoistway through a keyed box.
 5. Pressure gauge isolating valve, manually operable.
 6. Gate valve to isolate cylinder from pump unit.

7. Electrical solenoid for down direction control.
8. Emergency lowering by battery power, from the car control.
- I. Cylinder And Plunger:
 1. The cylinder shall be constructed of steel pipe of sufficient thickness and suitable safety margin. The top of the cylinder shall be equipped with a cylinder head with an internal guide ring and self-adjusting packing.
 2. The plunger shall be constructed of a steel shaft of proper diameter machined true and smooth. The plunger shall be provided with a stop electrically welded to the bottom to prevent the plunger from leaving the cylinder.
- J. Roller Chains: Two No.50 roller chains with 5/8 inch (16 mm) pitch. Minimum breaking strength 6100 lb (2773 kg) each.
- K. Leveling Device:
 1. The lift shall be provided with an anti-creep device which will maintain the carriage level within 1/2 inch (12 mm) of the top landing.
 2. All limit switch and leveling device switches shall be located in a position to be inaccessible to unauthorized persons. They shall be located behind the mast wall and be accessible through removable panels.
- L. Guide Yoke: The 2:1 guide yoke/sprocket assembly shall be supplied with two sprockets, roller guide shoes, bearings and guards.
- M. Call Stations: Provide key-controlled call stations for upper level and lower level on a stainless steel plate (Type 304 #4 stainless steel finish).
- N. Terminal Stopping Devices: Normal terminal stopping devices shall be provided at top and bottom of runway to stop the car positively and automatically. Micro switches shall not be used.
- O. Guide Rails and Brackets: Steel "C" guide rails and brackets shall be used to guide the platform and sling. Guide rails shall form part of the structural integrity of the unit and be integral to the mast enclosure, ensuring stability and minimum platform deflection when loaded.

PART 3 EXECUTION

3.1 EXAMINATION

- A. Do not begin installation until hoistway and machine room has been properly prepared.
- B. Site dimensions shall be taken to verify that tolerances and clearances have been maintained and meet local regulations.
- C. If substrate preparation is the responsibility of another installer, notify Architect of unsatisfactory preparation before proceeding.

3.2 PREPARATION

- A. Clean surfaces thoroughly prior to installation.
- B. Prepare surfaces using the methods recommended by the manufacturer for achieving the best result for the substrate under the project conditions.

3.3 LIFT INSTALLATION

- A. Install all the components of the lift system that are specified in this section to be provided, and that are required by jurisdictional authorities to license the lift.
- B. Trained employees of the lift contractor shall perform all installation work of this section.
- C. Adjust lift for proper operation and clean unit thoroughly.
- D. Instruct users in operation procedures and Owner's maintenance person in trouble-shooting and maintenance procedures.

3.4 PROTECTION

- A. Protect installed products until completion of project.
- B. Touch-up, repair or replace damaged products before Substantial Completion.

END OF SECTION

V1504

Vertical Platform Lift

PLANNING GUIDE

Part No. 000690
Copyright © 2010

Savaria Corporation
Lifts and Elevators
www.savaria.com

Support
107 Alfred Kuehne Blvd.
Brampton, Ontario, L6T 4K3, Canada
Toll free: (800) 791-7999
Fax: (905) 791-2222

